

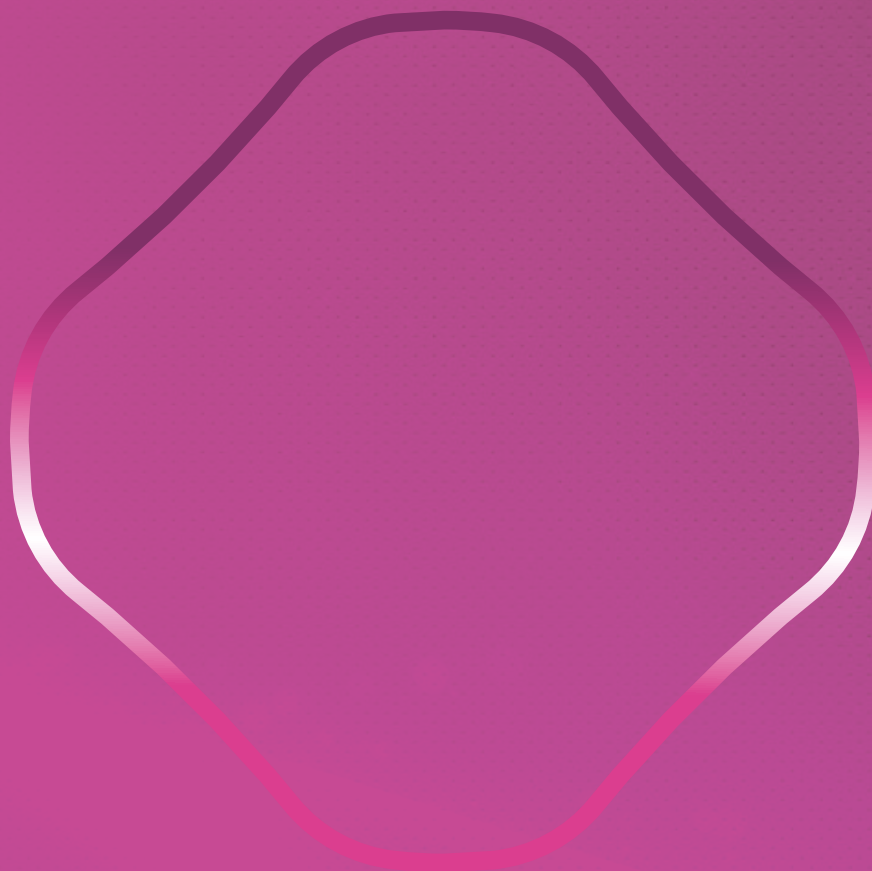

**bti**<sup>®</sup>

Biotechnology  
Institute



*BTI CORE<sup>®</sup> IMPLANTS*

**DO MORE WITH LESS**

Published by  
TEAM WORK MEDIA ESPAÑA  
© EDUARDO ANITUA ALDECOA

Photographs and infographics  
© BTI Biotechnology Institute

Layout and design  
TEAM WORK MEDIA ESPAÑA

Vitoria-Gasteiz · Spain 2024

All rights reserved. This manual may not be reproduced, saved in a retrieval system or transmitted in any way, by means of any procedure, whether mechanical, electronic, photocopies, slides, scanning or any other, without prior written permission from the author.

**"In times of change, learners inherit the earth, while the learned find themselves beautifully equipped to deal with a world that no longer exists."**

**Eric Hoffer (1902-1983)**  
*American writer and philosopher*



CONTENT





# What can CORE offer us ?

The shape of implants has evolved throughout history to adapt to the functional requirements of every situation. We've moved from screw-retained to self-screwing implants and witnessed several modifications to the shape of the body, apex and turns, trying at all times to improve osseointegration and the transmission of loads through them to the bone upon which they are seated.

The diameters of implants have also been greatly modified, achieving very narrow implants to adapt to areas where there is little space and wide implants for areas where there is more biomechanical demand. The length of the implant has also changed, going from what was considered "Standard" in the 70s (11.5 mm) to increasingly shorter lengths, with short and extra-short implants being launched onto the market that allow us to treat large atrophies vertically with less morbidity and minimally invasive surgical procedures.

All of these changes can only mean one thing: "implantology is constantly evolving". This evolution is based on being increasingly less interventional and managing to simplify our

surgical procedures, without reducing predictability in treatment. The BTI CORE® implants are born from this quest. This line allows us to reduce our implant stock, moving from multiple platforms and diameters to a reduced group that broadens the span of treatment in the majority of clinical situations.

Simplifying our selection of implants, added to a surgical protocol with less clinical steps, allows us to treat more cases in less time. Also, the implant's own features: surface, apex, platform change and Bioblock technology, which we'll explain below, provide us with the conditions we need in order to achieve high predictability in treatments.

The BTI CORE® range guarantees extraordinary flexibility in order to adapt to the different challenges when rehabilitating with dental implants, as well as streamlining procedures.

## WHAT MAKES IT DIFFERENT?

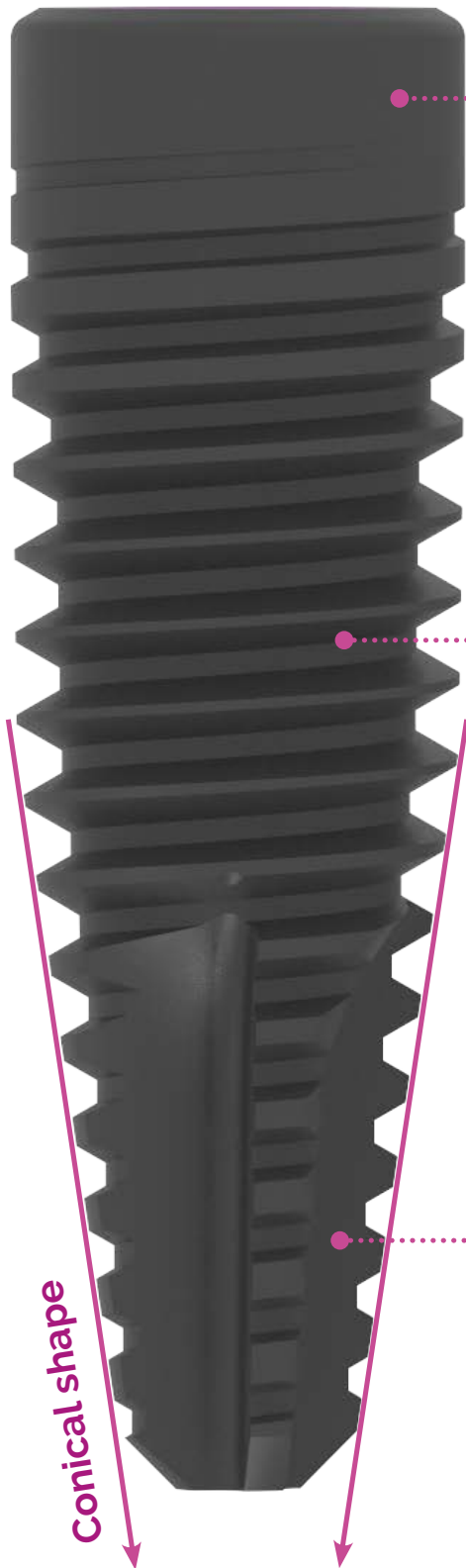

An internal tetra-lobe with a prosthetic emergence of 3.5 mm in diameter, that allows us to standardise the attachments we use.



Thanks to the properties of the UNICCA® surface, BTI CORE® implants provide greater bone stability and higher osseointegration.



Their apex has great advance capacity, facilitating the surgical procedure in any bone type.

## UNICCA® SURFACE

The BTI CORE® implant has a surface called UNICCA®. This surface is a chemical modification with calcium ions on triple roughness. Because of this, the implant has a wet appearance due to the natural hydration caused by the calcium ions, without needing to be immersed in a liquid solution.

The hydrophilic UNICCA® surface stimulates osteogenic activity, accelerating and improving the osseointegration of the implant from its insertion.

As well as the aforementioned surface characteristics, the presence of triple roughness from the neck to the apex is equally important.



Calcium ions on the surface.

## BONE

The BTI CORE® implant has **three well-differentiated areas across its whole length** to adapt to the different areas of the alveolar crest.

### NECK

The neck area of the implant is the one that is likely to be exposed to the oral environment over time due to small losses of crestal bone that can occur in the first few years after placement. This bone loss can be considered "normal" when it is lower than 1 mm in multiple prostheses and around 0.58 mm in single prostheses\*.

The roughness of the surface of the implants in the neck area is critical when exposed to oral microbiota. These surfaces accumulate and retain more plaque, especially motile organisms and spirochaetes. The roughness is required in order to stimulate bone growth towards the surface once the implant has been inserted but, at the same time, it is a high risk area for colonisation and the beginning of peri-implantitis. In the case of the UNICCA® surface by BTI, in addition to the hydrating effect of the calcium ions, the topography of the neck has been specially designed to favour the creation/maintenance of tissue when faced with bacterial colonisation.

### TURNS AND BODY

The roughness of these areas also has to be adapted to favour primary stability and the creation of new bone in the osseointegration phase. BTI CORE® implants have this different roughness on each area.

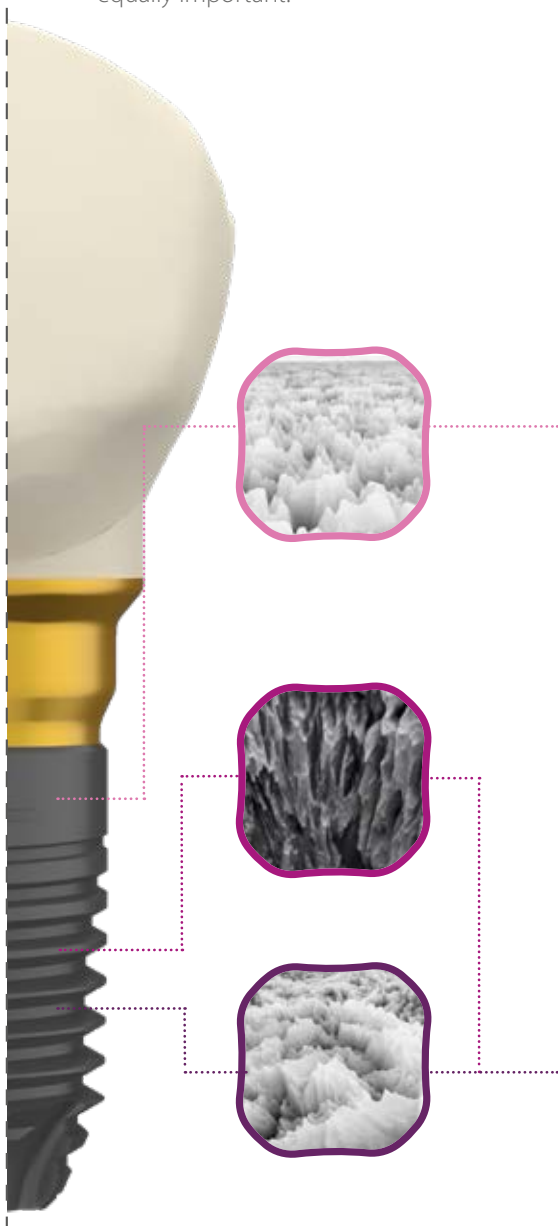

## FAMILY, PLATFORM AND CONNECTION

BTI CORE® offers great versatility in terms of diameters and lengths, maintaining one same platform (3.5 mm). This standardised platform allows us to use one prosthetic rehabilitation line and creates a more intuitive drilling sequence. The fact that the platform is reduced helps us to preserve soft tissue (less prosthetic emergence) and hard tissue (less compression in the most coronal area of the crest where bone loss is more frequent).

**Diameters range from 3.3 to 4.75 mm. This covers the majority of clinical cases that we face on an everyday basis.**

**Lengths vary from 4.5 to 15 mm to adapt to different clinical situations, among which we can find vertical atrophy (implants with a smaller length), sometimes extreme (implants of 4.5 mm in length), to situations where primary stability is required in order to achieve length (immediate post-extraction implants).**

BTI CORE® implants have an internal tetra-lobed connection with prosthetic components that are standardised for this connection, with the exception of the 4.5 mm implants, which has implications that should be explained separately, as we will do below. For the rest, including the largest platform diameters (from 3.5 mm), the components are the same across the whole line.

## Tetra-lobed connection

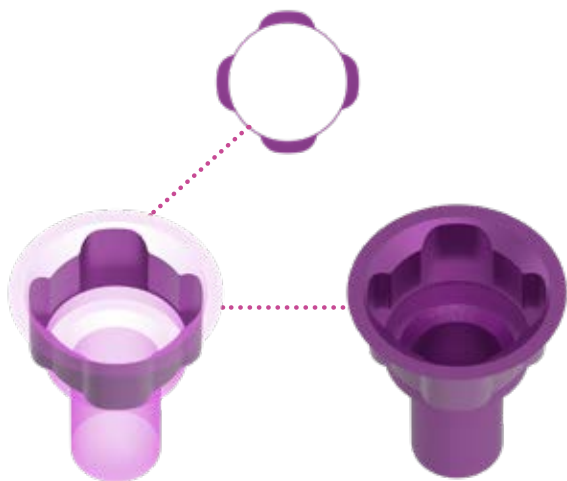

## 3.5 mm platform

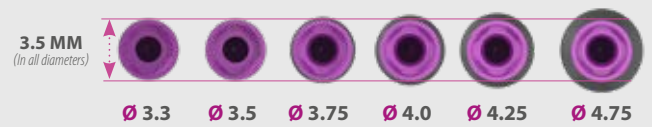

## Diameters

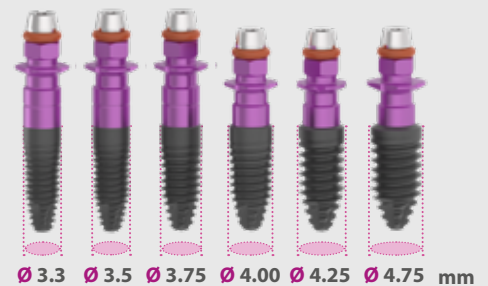

Different lengths, according to diameter, from 4.5 mm to 10-13-15 mm

## Lengths

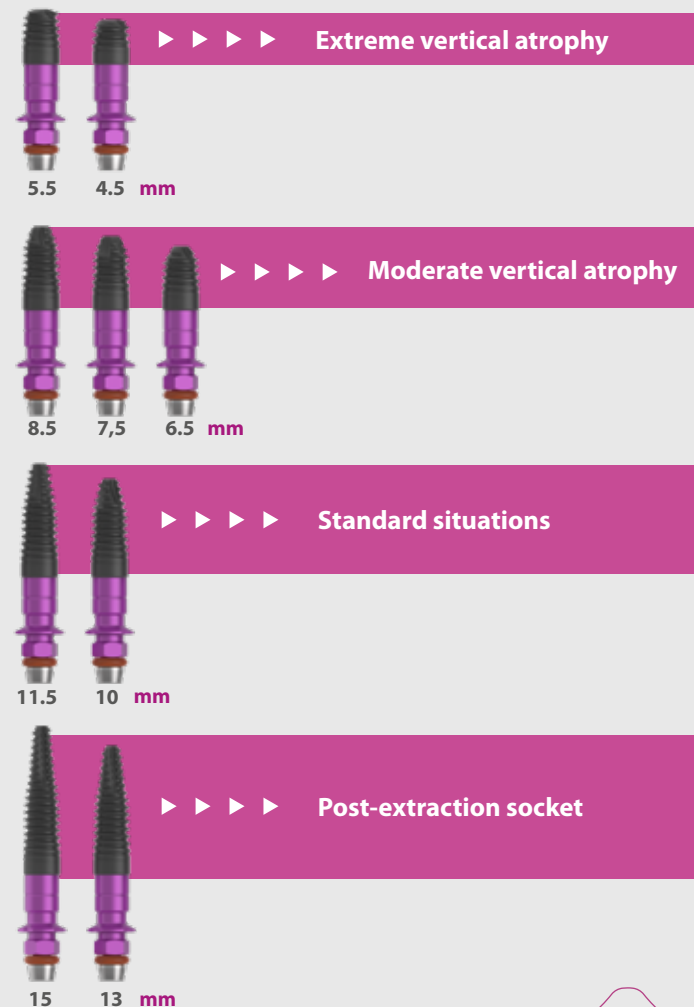

## BTI CORE® IMPLANT, 4.5 MM IN LENGTH



With short and extra-short implants (lengths from 5.5 to 7.5 mm) we can restore posterior sectors with vertical atrophy, both in the mandible or maxilla, atraumatically. Even still, there are cases with extreme atrophy where the residual bone volume prevents the direct insertion of extra-short implants in the lengths that have been marketed to date. This is where the idea for the 4.5 mm implant came about.

With this implant, we can apply a minimally invasive approach to crests with a residual bone height from 3.5 mm, inserting the implant at a juxta-osseous level, in cases with a height of at least 4.5 mm, or at a slightly supra-osseous level, in cases with greater atrophy, achieving guided bone regeneration that subsequently allows the crest to be lifted to the level at which the platform can be fitted. We can also resolve cases of crestal elevation with a minimum bone volume using atraumatic elevations.



Direct insertion of a 4.5 mm length implant in an edentulous crest in the posterior maxilla sector.



Residual crest of 3.5 mm with insertion of a 4.5 mm implant with slight crestal elevation.

Coupling this new implant length with the reduced CORE platform provides us with the versatility for atraumatic treatment in extreme situations, both in vertical and horizontal atrophies, even when both types are combined.

**The 4.5 mm implant has some specific components due to the reduced height of the internal screw channel, adapted to the minimum implant length.** Among these components, we find the extender applicator, required to finalise the insertion of the implant directly onto the connection and its own MULTI-IM® abutment, given that **this implant is aimed at restoration as part of a splinted structure (we don't recommend it as a single alternative).**

Once the specific abutment has been used, we can use the standard prosthesis components for the selected platform (straight or expanded).

### SPECIFIC COMPONENTS

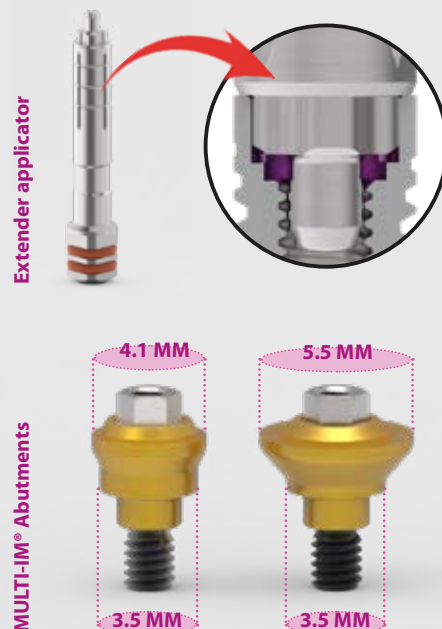

## BIOBLOCK® CONCEPT

In current implantology, besides classic concepts such as the length and the diameter, we now know a lot more about the behaviour of each of the tissues that are involved in osseointegration (at a bone level) and bio-integration (at a gingival level). This has led us to consider whether a specific design of implant-prosthesis based on different surfaces adapted to the different tissues that they interact with (cancellous bone-implant body, cortical bone-implant neck, connective tissue-prosthetic component, epithelial tissue-prosthetic component), could mark the difference in terms of the success rates of our treatments.

This concept is based on the development of different surfaces at the implant-prosthesis join which is in contact with the different areas for which it is intended – bone and soft tissue – thus achieving successful integration as well as a hermetic seal.

The advantages that the surface brings to this bioblock concept are, mainly: bone adaptation due to the triple roughness of the implant body (as mentioned above) and the calcium ions that increase bone formation around said surface, as well as a reduction in bacterial adhesion. Both processes accelerate osseointegration and reduce the risk of peri-implantitis, respectively.

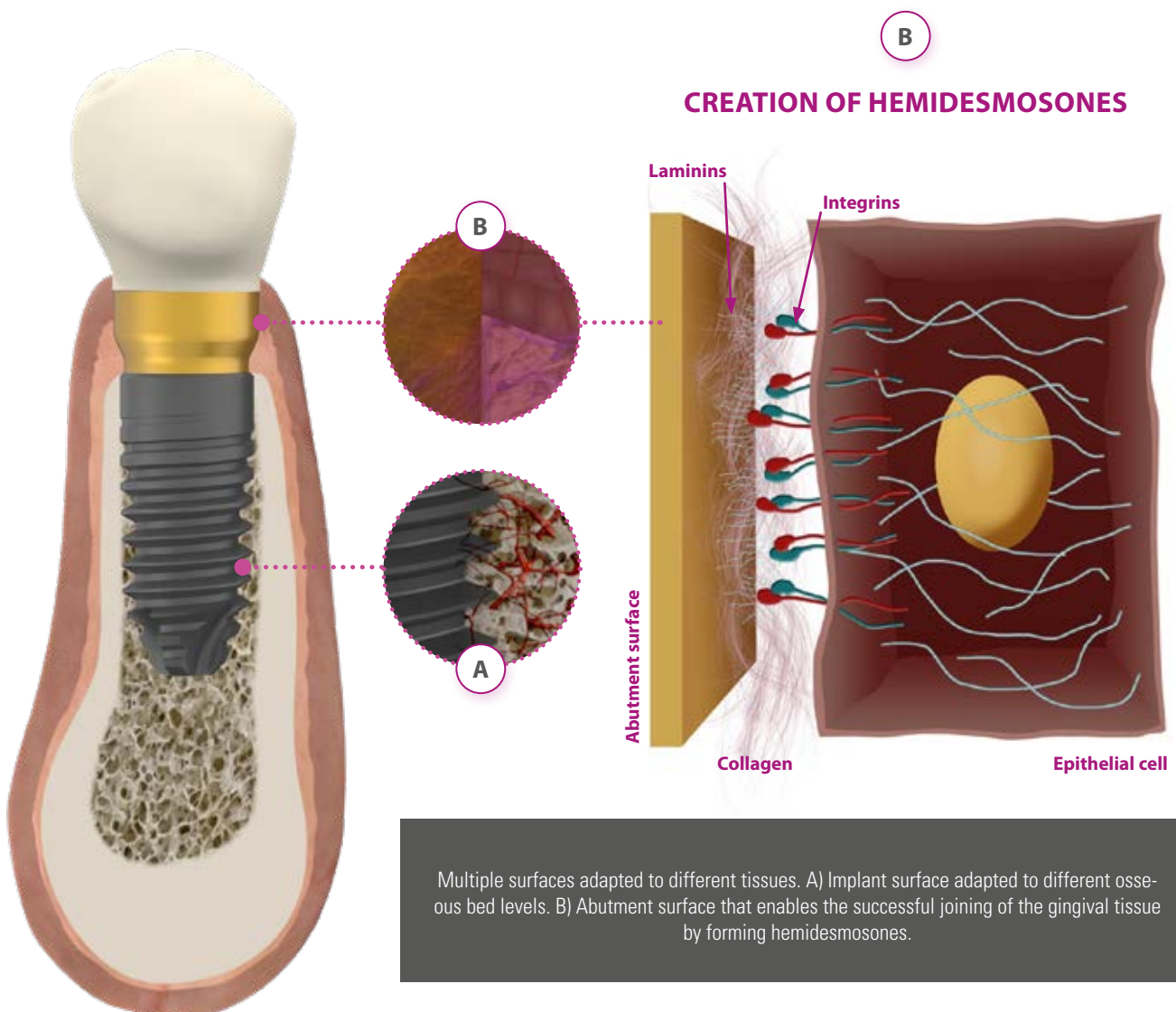

We mentioned the characteristics of the implant and its surface and the advantages provided by bioblock before, but those related to the prosthesis (gingival tissue) are the following:

- 1 The soft tissue intervenes in the bioblock through the prosthesis-gingival tissue union of the peri-implant sulcus. This union can be created using an abutment for cementing, and the ceramic and metal of the prosthesis, when using a cemented prosthesis or a direct-to-implant one or by using an intermediate component (abutment) that is specifically adapted for this function. At this point, the surface treatment of the abutment is key and should ideally avoid bacterial adhesion and favour the union of epithelial cells. The Ti-Golden surface treatment offers us these advantages, inhibiting the early adhesion of the bacterial strains that are most common in the oral cavity (*Streptococcus mutans*, *S. Sanguinis* and *Aggregatibacter Actinomycetemcomitans*).

**SURFACE TYPES** →

TiGolden

Prosthesis laboratory

Machined implant

Rough implant

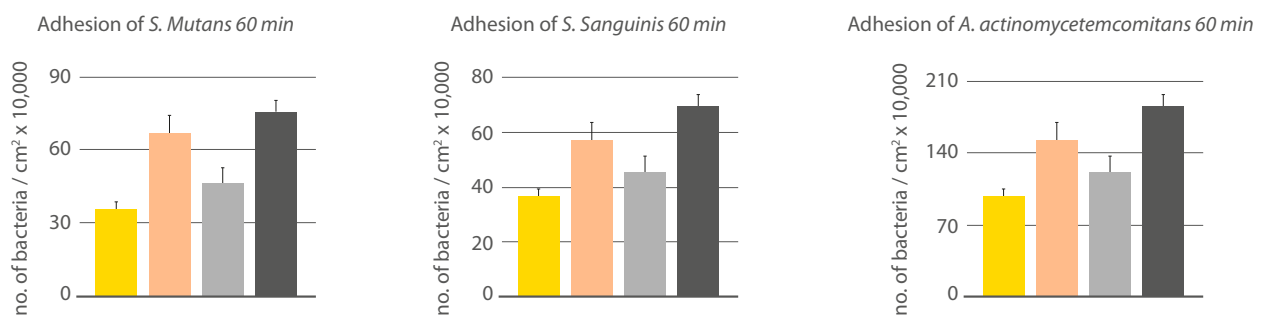

Results of the cultures of three bacterial strains representing the microbiome in the oral cavity with a real flow of natural saliva from healthy donors after 60 minutes exposure. The bacterial adhesion on the different surfaces was analysed. In all cases, the BTI Ti-Golden® surface of the abutment recorded significantly less bacterial adhesion than the other surfaces evaluated.

- 2 The roughness of the abutment surface is another key point as it should be rough enough to be able to stimulate the adhesion of the gingival fibroblasts, without being too rough (which would result in the accumulation of bacterial plaque) or too smooth (which would prevent this adhesion).

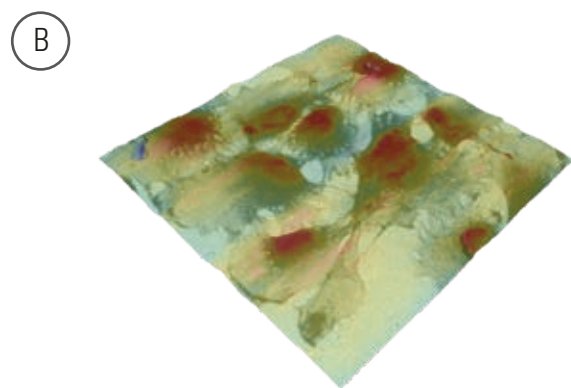
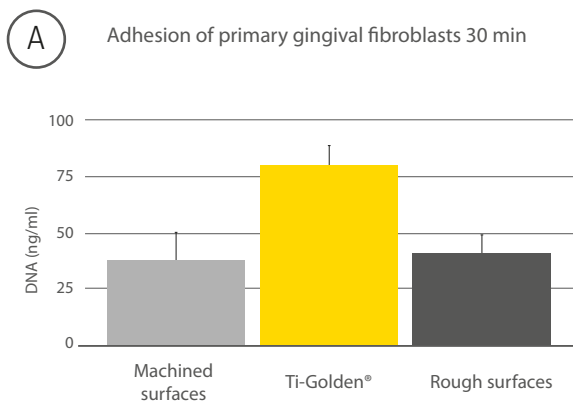

[ A ] Results of the cell cultures of primary gingival fibroblasts on smooth (machined) and rough (SLA) surfaces and on the Ti-Golden® surface. The adhesion at 30 minutes of culture is significantly higher on the BTI Ti-Golden® abutment surface.

[ B ] Three-dimensional restorations using scanning electron microscopy of the layer of gingival cells adhered to the Ti-Golden® surface. We can see the cytoplasmic extensions and the cell filopodia anchoring themselves in the nanotexture of the surface. This is a cell development typical of cells that are well adhered and functional.

## BTI CORE® AND ITS MACROSCOPIC DESIGN

### GENERAL MORPHOLOGY OF THE IMPLANT

The BTI CORE® implant has a conical morphology which provides a series of advantages, such as:

1. **Greater primary stability**, even in cases where bone density is low or in post-extraction implants.
2. **Smaller volume at the apex**, suited to cases where compression here by a larger apex may be detrimental.

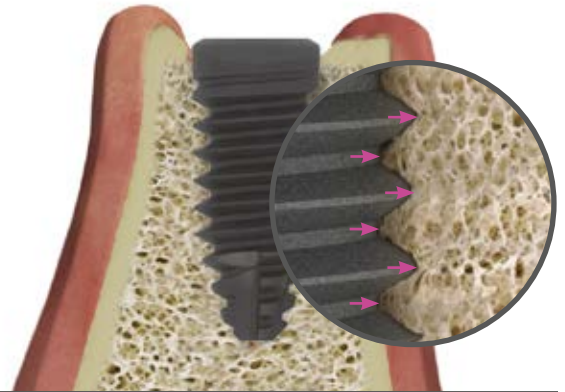

The CORE morphology adapts to the post-extraction socket, increasing stability by compressing the bone due to its drilling and insertion sequence.

### APEX

BTI CORE® implants of 6.5 mm length or more have a conical apex, reducing the diameter at the tip to 2.1 mm. This has to be taken into consideration, as it facilitates its insertion, improves its advance and is critical in limited mesio-distal spaces. We should also bear in mind that this conical shape doesn't exist in lengths shorter than 6.5 mm.



### Conical apices

BTI CORE® implants of 6.5 mm or more in length have a conical apex.

## THREAD: EVOLUTION OF THE THREAD ACCORDING TO THE DIAMETER

The thread on BTI CORE® implants varies according to the diameter, allowing us to use a thread with a greater advance capacity with implants that have a larger diameter, which grants them better anchoring, making it the best choice for bone defects and post-extraction sockets.

We can divide the threads into the following types:

### TYPE 1 THREAD

For 3.3 and 3.5 mm diameter implants. Has 0.6 mm between turns and a thread depth of 0.25 mm. The fixing of this implant is achieved more due to the morphology (conical) and adaptation of the drilling sequence than the penetration of the thread, as it is smaller. **These implants are key for areas where there are problems with the mesio-distal space and horizontal atrophy where less compression will be generated in a bone with less vascularisation.**

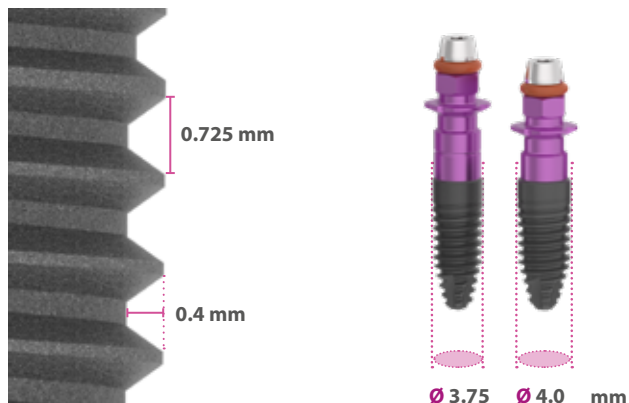
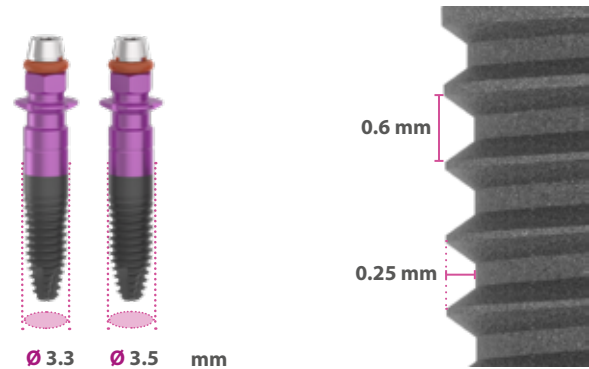

### TYPE 2 THREAD

For 3.75 and 4.0 mm diameter implants. Has 0.725 mm between turns and a thread depth of 0.4 mm. Has a greater capacity for primary stability, despite creating light compression with the turns as it is somewhat more aggressive. **Suitable for lower density bones where fixing by means of compression is necessary.** The larger diameter of the implant makes it especially suitable for narrow bone crests that are not overly atrophic (approximately 6 mm) making cortical compression less drastic than in the previous group.

### TYPE 3 THREAD

For 4.25 and 4.75 mm diameter implants. Has 0.9 mm between turns and a thread depth of 0.55 mm. This grants it a greater threading capacity because its turns are more aggressive and have a bigger gap between them. They are suited to bone crests without atrophy to achieve suitable primary stability without covering all of the existing bone. **Implants in this group are ideal for restoring all crest types, preserving the osseous bed as much as possible,** as they are not particularly affected by the compression of the turns because they have better vascularisation. In addition to this, the fact that its width is greater than its platform allows the crestal bone to be preserved by changing the platform at the implant itself (switch platform). They are, therefore, **the implants that are most frequently used in clinical cases.**

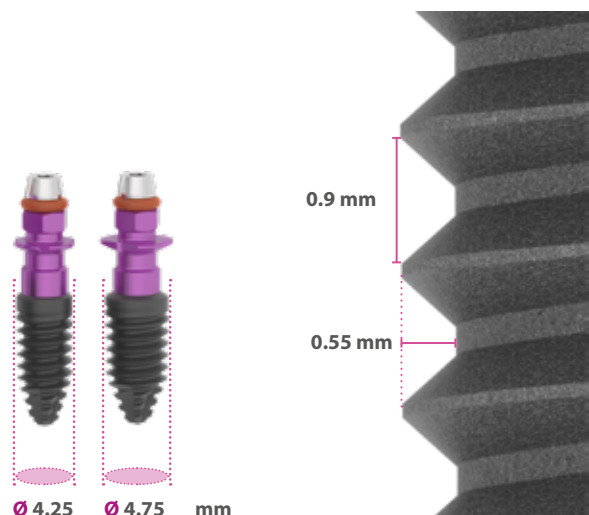

## IMPLANT MOUNT TRANSPORTER

In implants most suited to posterior restoration (4, 4.25 and 4.75 mm in diameter) shorter transporters have been developed to favour their insertion in the posterior sectors, where the conventional transporter makes it difficult to insert the implant correctly.

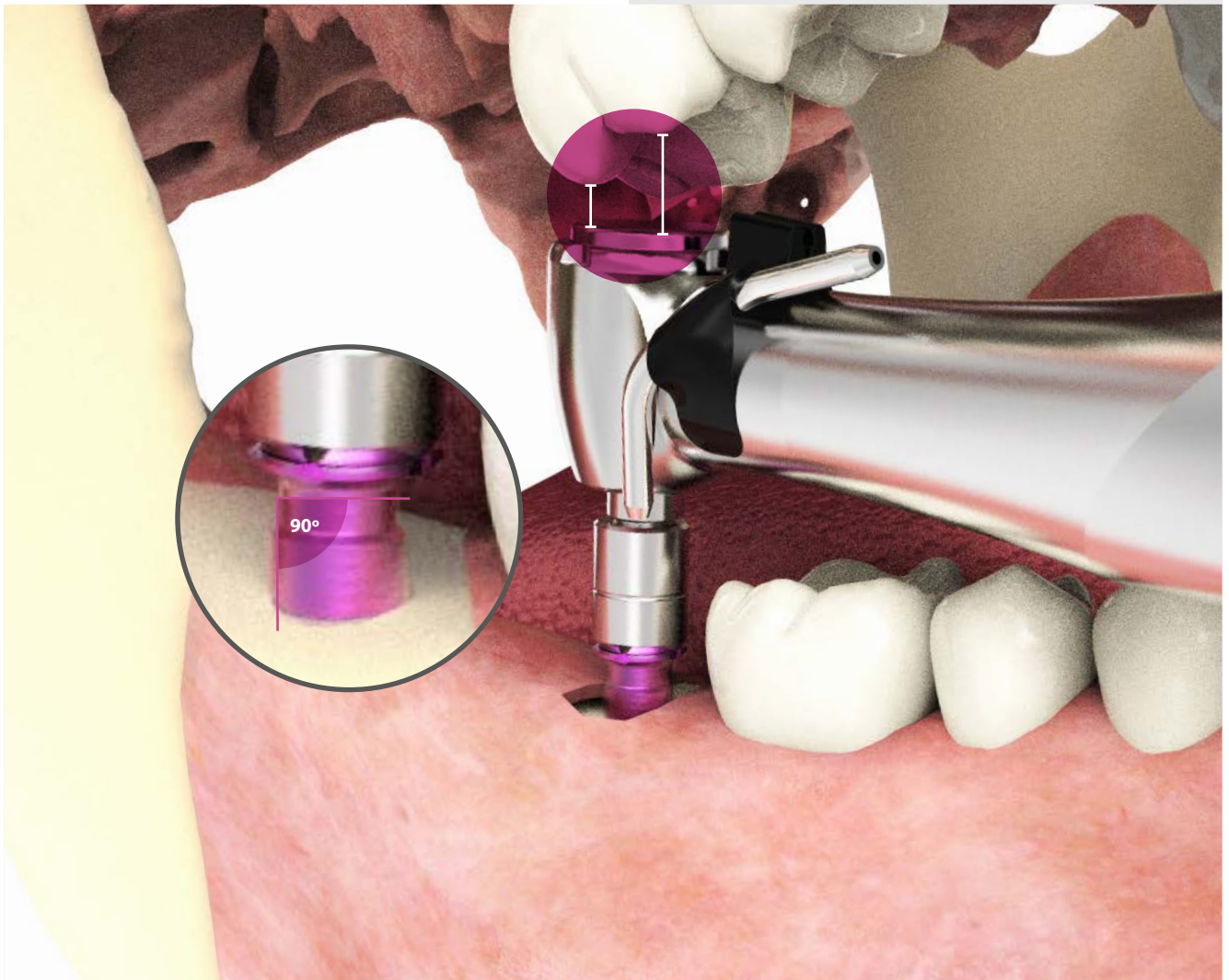
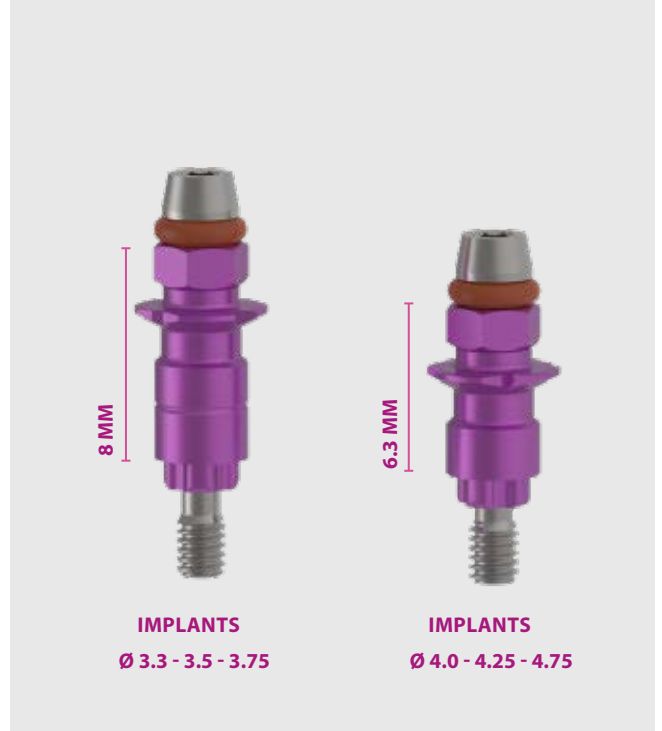

The new 6.3 mm transporter allows us to insert the implant at a right angle thanks to the margin offered in terms of the teeth on the opposite arch.

## BIOMECHANICS OF BTI CORE® IMPLANTS

Biomechanics in implantology makes it possible to foresee and minimise overloads that the mechanical system (prosthesis + screw and/or interface) and the bone structure that houses it may suffer.

The estimation of the stresses and how they are transmitted to the elements that make up part of the ensemble is done through finite elements. We can define the studies using these elements, which are a calculation method used in engineering based on considering the body or structure divided into discrete elements, with certain conditions linking them to each other, generating a system of equations that allows us to predict the stresses and deformations of the ensemble under previously defined boundary conditions. These calculations can be displayed using colorimetric scales which makes them easier to understand.

These finite element studies allow us to find out how an implant will behave when subjected to a load in different scenarios and even to compare them with other implants of different lengths and diameters. Using these data, we can build our treatment plan based on the behaviour of each of the implants that will be used in rehabilitation, using the biomechanical behaviour of the ensemble as a guide. The long-term predictability of implants is based on different factors (bone type, parafunctional activity, hygiene), as the biomechanical requirements to which they will be subjected while being used is a key point.

More than 80% of the load is supported by the first millimetres that are closest to the surface, leaving only 20% of the load to be supported by the rest of the length of the implant.

### Vertical load / 200N

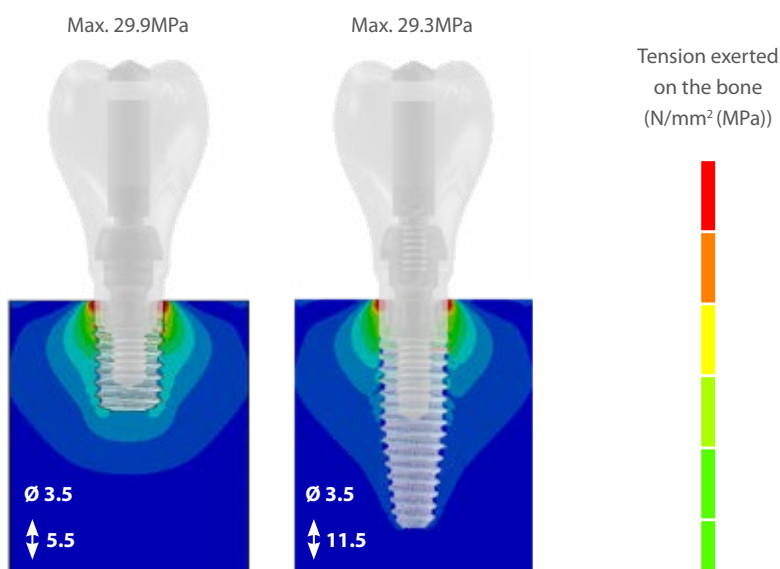

### Angled load 30° / 200N

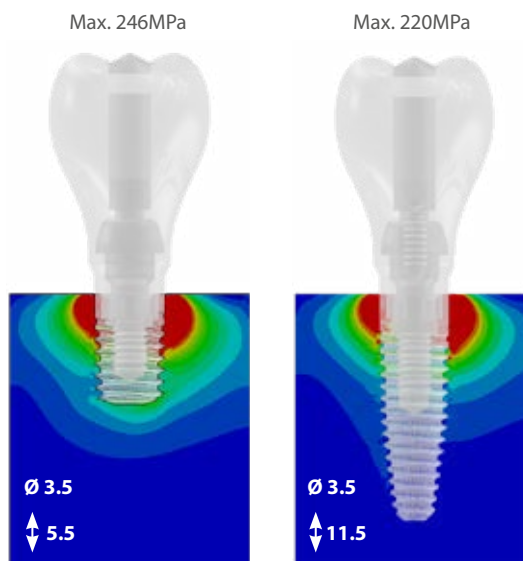

Comparison of the vertical and angled load in BTI CORE® implants of different lengths.

Bone quality and quantity is important when predicting how it will behave when faced with physiological and pathological loads. To find out the bone type we're facing when inserting an implant and to establish different protocols for said insertion based on this, different bone classifications have been drawn up. The most widespread is that of bone quality and density by Lekholm and Zarb (1985), which classifies the bone based on its percentage of cancellous and cortical bone into IV types. Subsequently, our work group modified this by adding two more subtypes (type 0 and type V), the most thorough classification being the one shown in the table.

Finally, regarding the number of implants and their splinting, we recommend, whenever possible, splinting the implants when the prosthesis is to be constructed on more than one implant. This distributes the stresses and improves how the ensemble behaves from a biomechanical point of view.

BONE TYPE	HISTOLOGY (TYPE OF BONE FOUND)	LOCATION	UNITS HU (HOUNSFIELD)
0	Extremely dense cortical bone only	Posterior and anterior mandibular areas with extreme reabsorption	1,400-1,200 Hu
I	Almost exclusively dense cortical bone	Anterior mandibular area	1,200-1,000 Hu
II	Dense cortical bone (3-4 mm) surrounding dense cancellous bone	Anterior and posterior mandible area	1000-850 Hu
III	Thinner cortical bone (1-2 mm) surrounding dense cancellous bone	Anterior and posterior area of the maxilla and mandible	800-500 Hu
IV	Very thin cortical bone (0.5 mm) surrounding low density cancellous bone	Posterior maxillar area and posterior mandibular area	500-400 Hu
V	Very low quality cancellous bone	Posterior areas of the jaw	350-100 Hu

Classification of bone types according to the bone density combined with the Hounsfield Units obtained from the dental CBCT. (Anitua et al., 2015)

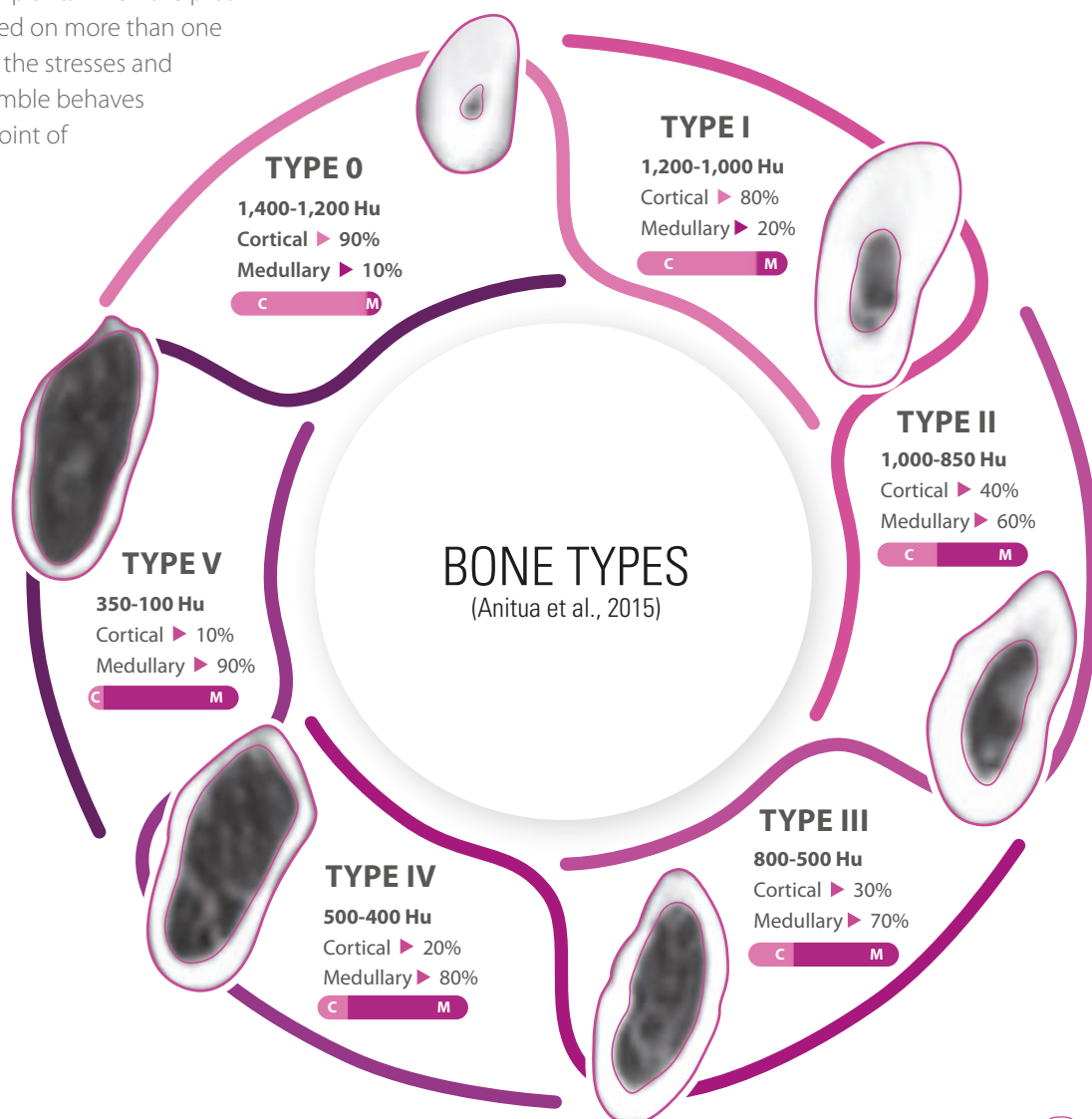

# Use of the implants

# CORE

BTI CORE® implants allow a reduction in time and costs in clinical practise, requiring less drills and a small surgical box to keep them in.



## KCQ5 SURGICAL BOX

The surgical box for inserting BTI CORE® implants is based on **ease of use and a reduced number of drills.**

2 initial drills, 1 pilot and drills increasing in diameter that allow us to fix the perforation site before we start to drill the neo-socket.

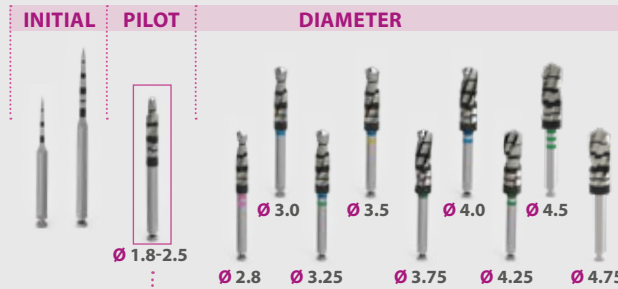
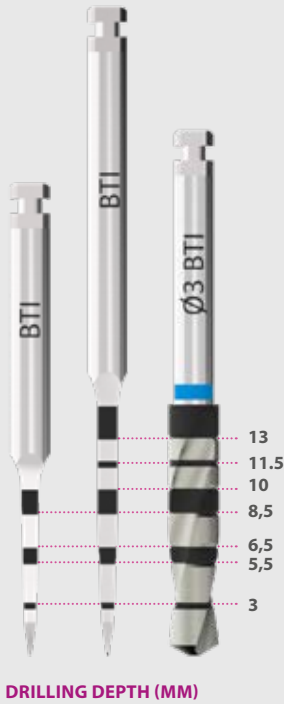

The pilot drill has a unique design with two different diameters in one same drill.

For cases where we need a longer drill, we have a **drill extender** which gives us a longer length.



The box also comes with a surgical multitorque wrench, an open-end wrench and a fittable handle where we can insert the screwdriver ends. It can be used manually.



Transporter to insert the implant.

Implant extender applicator.

Adaptor for surgical dynamometric wrench which allows us to finalise the insertion of the implant.

Hexagonal screwdriver tip that, coupled to the latch-type adapter handle, creates a screwdriver that allows us to remove the implant transporter manually.

Large hexagonal torque tip and parallel walls.

Torque tip that fits into the handle and allows abutments to be inserted manually or torque to be applied.

Platform indicators that allow us, at the beginning of the surgery, to find out the position of the implant platform at the end of drilling and view the platform in relation to the surrounding bone.



# Drilling sequences recommended (7.5 - 15 mm)

The morphology of the BTI CORE® implant simplifies the drilling sequence. Its conical apex and the cylindrical part of the body means that a limited number of drills are used, achieving effective stability in very different clinical situations.



## Ø3.5mm diameter of prosthetic platform

### DRILLING DEPTH INDICATED

- Total depth of implant
- 6.5 mm drilling depth
- 2-3 mm drilling depth



Type	Hounsfield	DRILL	SPEED	IRRIGATION
0	1400 - 1200	Initial drill	800 - 1000 rpm	yes
I	1200 - 1000	Drills	50 - 75 rpm	no
II	1000 - 850			
III	800 - 500			
IV	500 - 400			
V	350 - 100			

NOTE: These sequences are standard and the bone density detected in the planning stage and the height of the cortical bones must always be taken into account to achieve effective fixing.

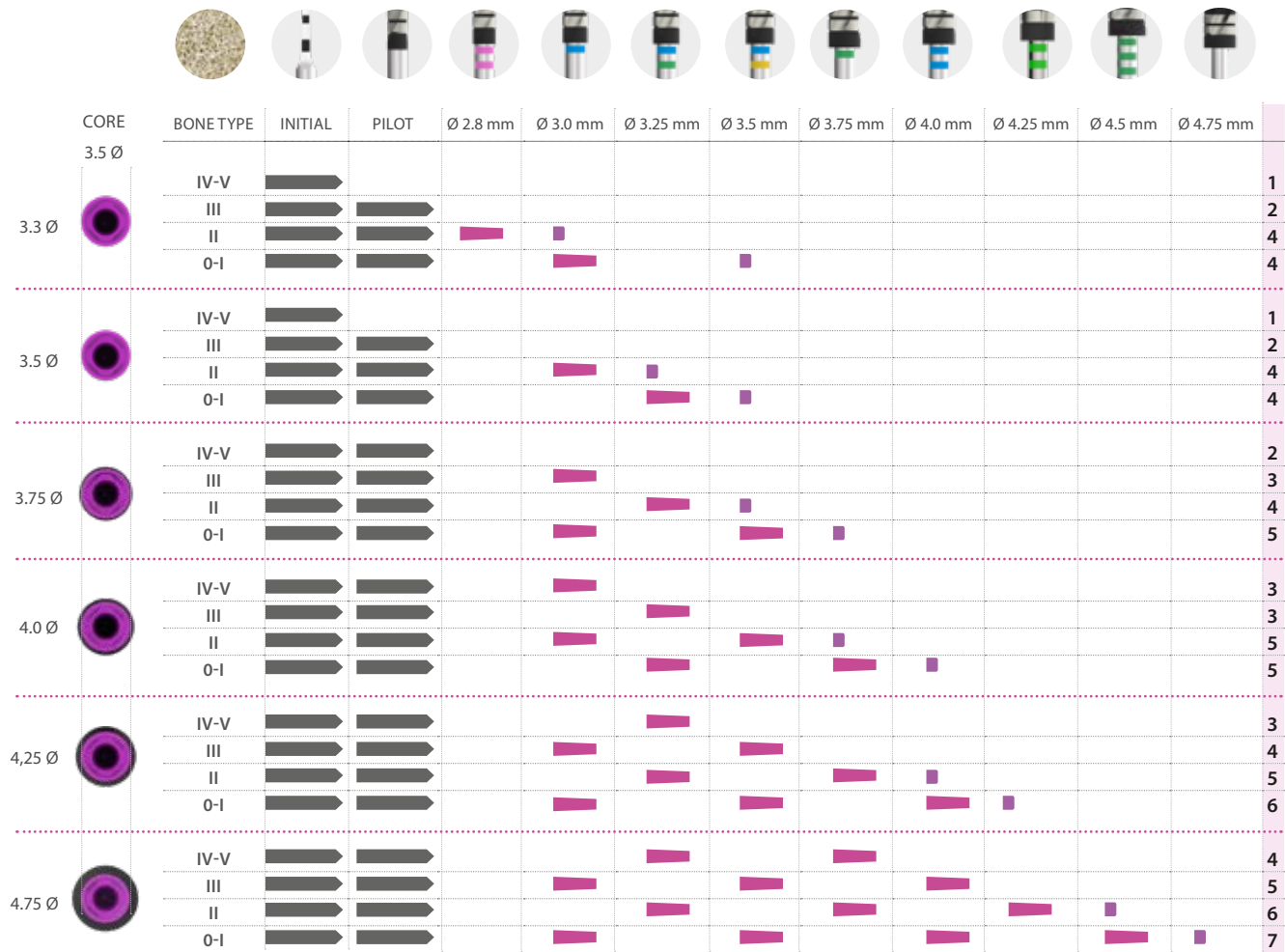

# CORE

The recommended drilling sequence is based on using a larger diameter drill for the area corresponding to the implant body, and an 1.8/2.5 mm pilot drill for the apex portion.

BONE TYPE II

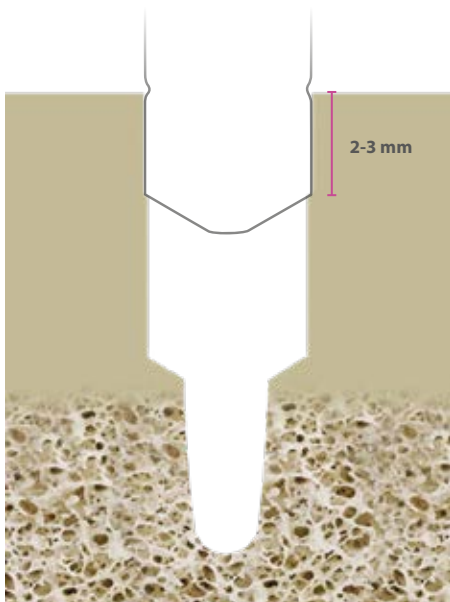

Then, diameter adjustments are made depending on the bone type, to achieve suitable stability.

**In osseous beds with higher density, it may be necessary to use a larger diameter drill for the first few millimetres of the crest (2-3 mm),** to achieve a better fitting of the neck, this drill often being the same diameter as the implant.

These drilling sequences, with different heights and diameters for the formation of the neo-socket, allow us to adapt the drilling to each bone type and cortical thickness, making them much more precise than if we resorted to using conical drills, which would use the same profile for all sockets, unable to adapt to each specific clinical case.

They are, therefore, **simplified drilling sequences with a maximum of 7 drills.**

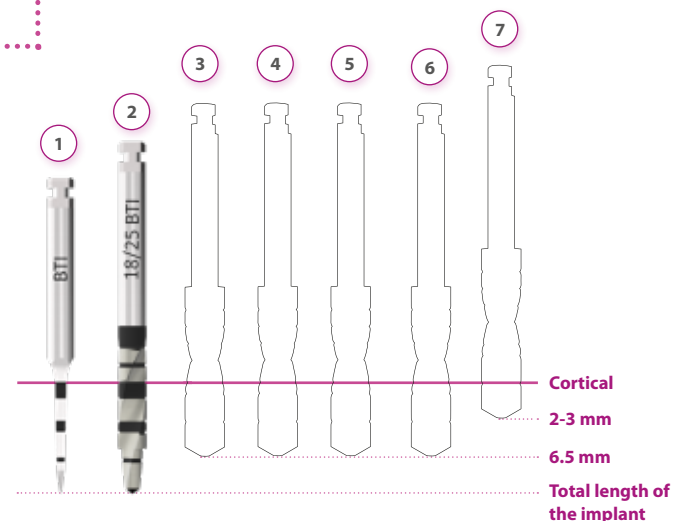

## DETAILED DRILLING SEQUENCE ACCORDING TO BONE TYPE

### 4 MM IMPLANT IN BONE TYPE IV-V

The low density of the bone in this case will make it more difficult to achieve adequate primary stability if we drill excessively. Therefore, **our drilling will stop at 1 mm from the diameter of the implant at a depth of 6.5 mm.** At full depth of the implant length, only the pilot drill will be inserted (1.8-2.5 mm).

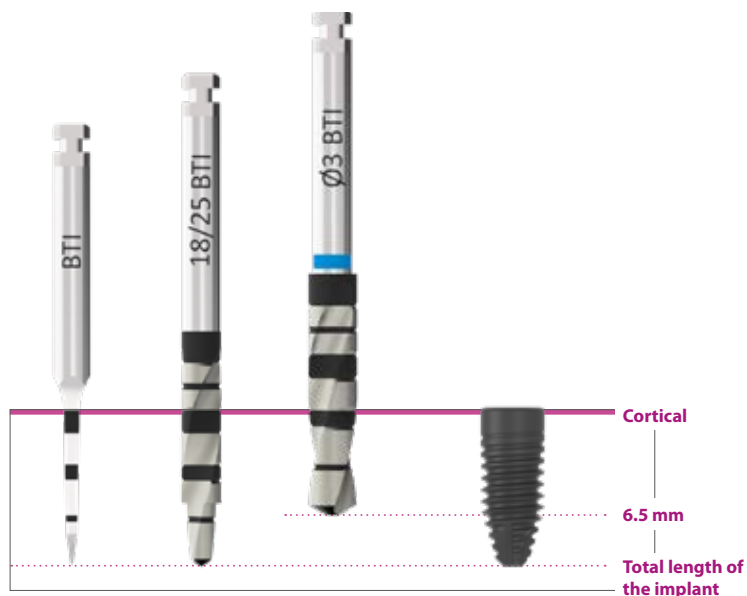
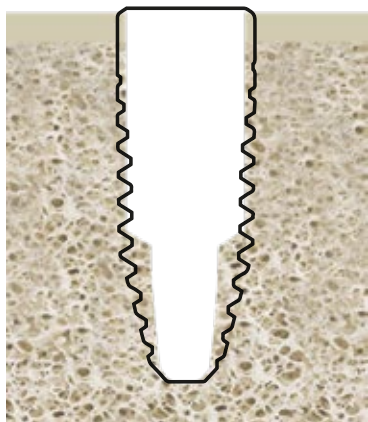

### 4 MM IMPLANT IN BONE TYPE III

In this bone of medium density, there is enough cortical to give us good primary stability. For this reason, we will drill with the double diameter drill (pilot 1.8/2.5 mm) at full length and, afterwards, with the 3.25 mm to 6.5 mm drill, refraining from drilling the portion corresponding to the apex more than 2.5mm to achieve progressive implant compression and primary stability.

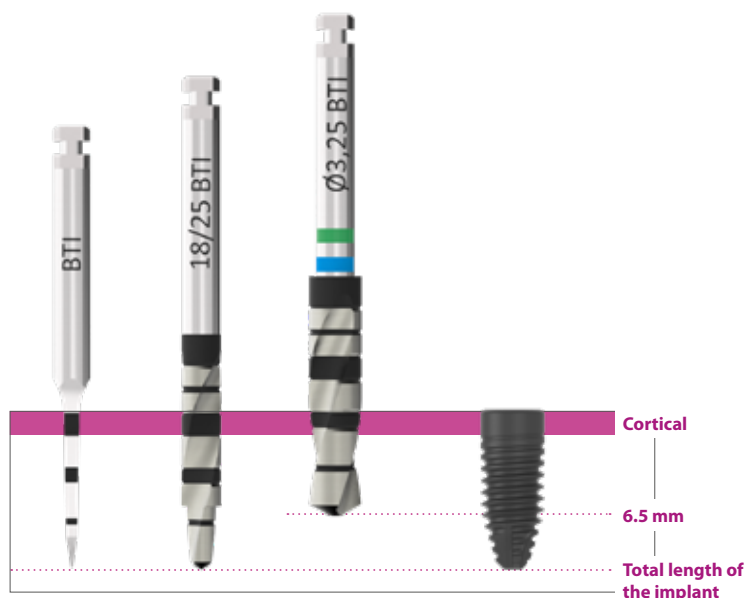
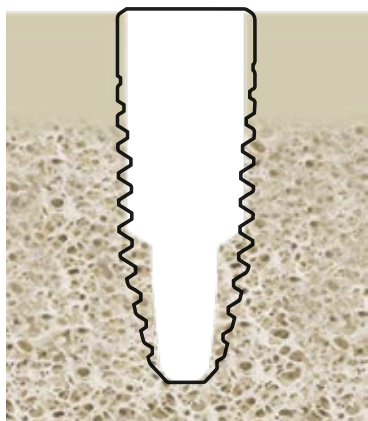

## 4 MM IMPLANT IN BONE TYPE II

This bone is highly compact with a very marked cortical bone that can exert pressure on the neck area. For this reason, we'll work with the pilot drill at full length and, afterwards, at 6.5 mm the 3 and 3.5 mm drill. Added to this is the drilling of the neck area (2-3 mm) with the 3.75 mm drill (0.25 mm less than the implant diameter) to leave the neck seated without pressure, as this is an area of low vascularisation which can cause subsequent bone resorption.

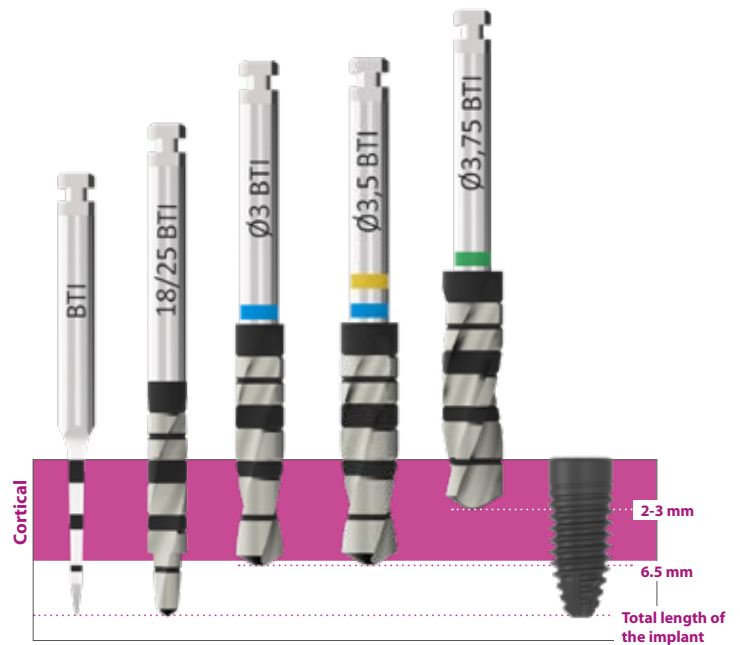
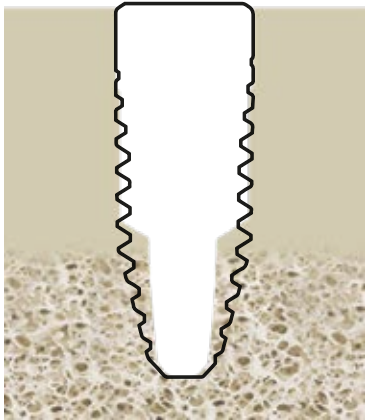

## 4 MM IMPLANT IN BONE TYPE I-0

Type I and type 0 is a bone where almost the entire implant will be inserted into cortical bone, with little vascularisation and high density. For this reason, we'll work with the pilot drill at full length and, afterwards, the 3.25 and 3.75 mm drill at a length of 6.5 mm. The difference compared to the previous bone type is that the crestal area will be drilled at the same diameter as the implant (4 mm) with a depth of 3 mm.

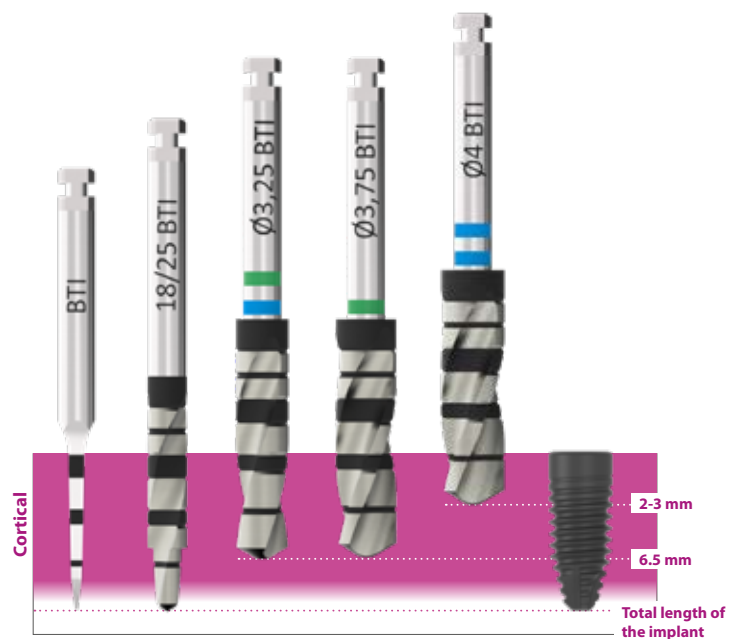
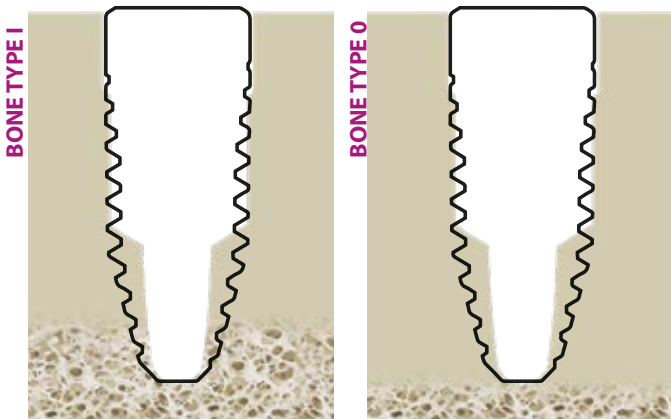

## DRILLING SEQUENCES RECOMMENDED FOR EXTRA-SHORT IMPLANTS

The drilling sequence of these implants varies compared with longer CORE implants (7.5 to 15 mm), to adapt the neo-socket to the morphology of the implant without creating compression in the critical areas and guaranteeing correct primary stability, a key factor in this type of implant. Implants that are 4.5, 5.5 and 6.5 mm in length have a flat apex

The drilling sequence is adapted to the walls and apex, introducing the **front cutting drills** to the total length. Front cutting drills **has a specific morphology to only cut in the area where it is active but is extremely conservative with adjacent anatomical structures** (such as the dental nerve in the mandible and the maxillary sinus in the superior maxilla).

Manufactured in a range of diameters, according to the neo-socket it's used on (3 - 3.5 - 4 and 4.5 mm). In addition to this, it has drilling depth marks at different levels to tell us where we're working at all times and allow us to calculate the drilling depth.



### Extra-short

Its blades allow a safe advance, mounted on a flat apex, arranged in a circular shape around its axis. This design allows us to drill safely by removing minimal volumes of bone slowly.



### FRONT CUTTING DRILLS Drilling depth and diameters



Depending on the bone type we're dealing with, we'll either use the larger or smaller diameter front cutting drill, adapting to the osseous bed and achieving compression (cases with decreased primary stability) or avoiding compression (cases with high density).

# Drilling sequences **recommended**

(4.5 - 6.5 mm)

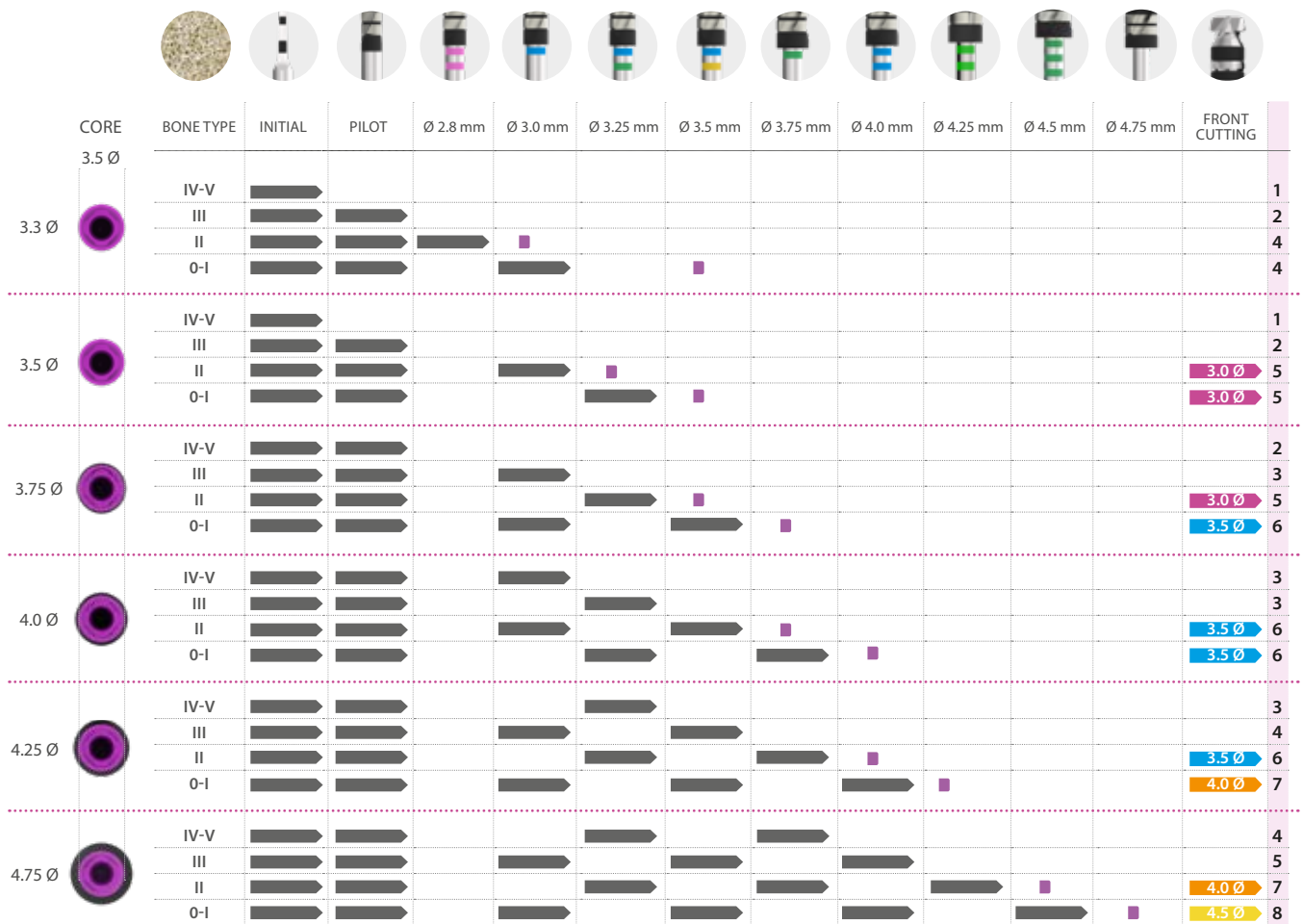

## Ø3.5mm diameter of prosthetic platform

### DRILLING DEPTH INDICATED

- Total depth of implant
- 3.0 Ø → Total depth of implant with specified diameter front cutting drill
- 3.5 Ø → Total depth of implant with specified diameter front cutting drill
- 4.0 Ø → Total depth of implant with specified diameter front cutting drill
- 4.5 Ø → Total depth of implant with specified diameter front cutting drill
- 2-3 mm drilling depth



Type	Hounsfield	DRILL	SPEED	IRRIGATION
0	1400 - 1200	Initial drill	800 - 1000 rpm	yes
I	1200 - 1000	Drills	50 - 75 rpm	no
II	1000 - 850	Front cutting drills	50 - 75 rpm	no
III	800 - 500			
IV	500 - 400			
V	350 - 100			



# The platform **CORE** and rehabilitation requirements

## **Which platform best suits my needs?**

The morphologies of implants, as well as their size and length, have constantly been evolving since their initial applications, where all implants had similar characteristics, diameters and lengths. Other key points have also changed, like the surface, the thread and the apex. Along with these

characteristics, the implant platform has also changed from the initial "standard" or "universal" platform to wide or narrow platforms with variations to adapt better to different clinical situations and emergencies.

## REDUCED PLATFORM: LESS IS MORE

A reduced implant platform and the use of an abutment allow greater stability in soft tissue. **What's more, from a prosthetic point of view, if that abutment is expanded, we maintain the same restorative emergence.**

With CORE, we can also make this change, in addition to the gain in width at bone level that we already have compared to larger diameter platforms.

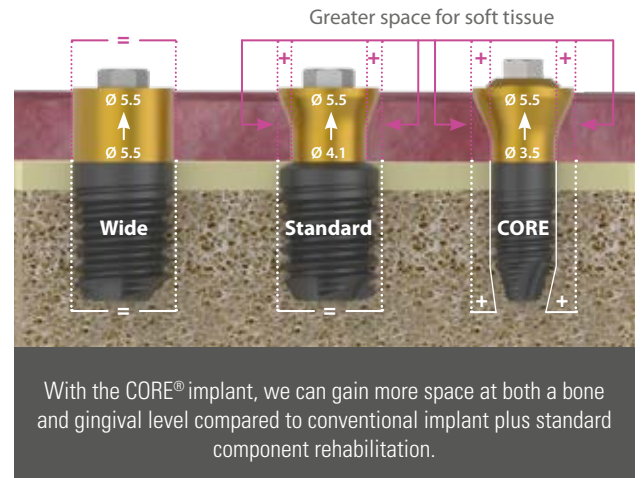

Narrow platform implants allow us to gain more available bone in the most critical area (crestal area). The reduced emergence in the narrow platform, even in larger diameter implants, therefore provides us with extra bone volume when dealing with the most compromised cases, with greater horizontal resorption.

## CORE Platform

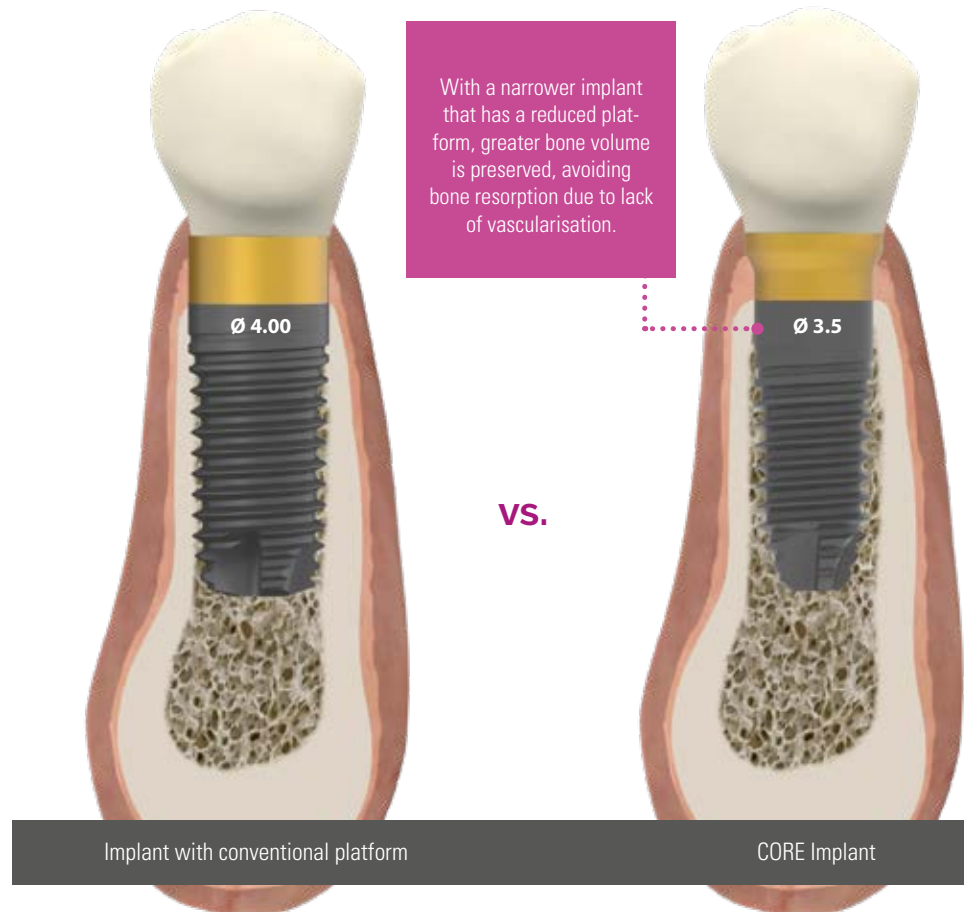
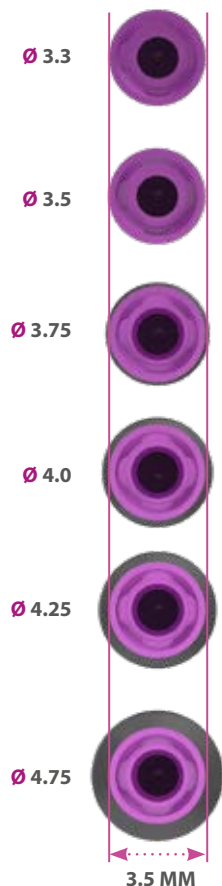

Biomechanically, narrow implants behave in a similar way to wider implants, as long as they are splinted. Therefore, choosing an implant with a smaller diameter and reduced platform provides us with two main advantages:

1. **Less bone volume required.**
2. **More bone tissue surrounding the implant in the most critical area, which will suffer greater stress in the load.**

**CORE implants with a narrow platform facilitate rehabilitations, improving emergence, reducing the bone volume necessary for insertion (requiring fewer extra surgical procedures, such as regenerations and grafts) and using a lower percentage of available bone.**

In turn, this provides us with two additional advantages:

1. **It reduces tooth-implant distances.**
2. **It preserves more osseous bed as it isn't invaded by the implant being inserted, key when thinking about future re-treatments.**

## BTI CORE® facilitates rehabilitations

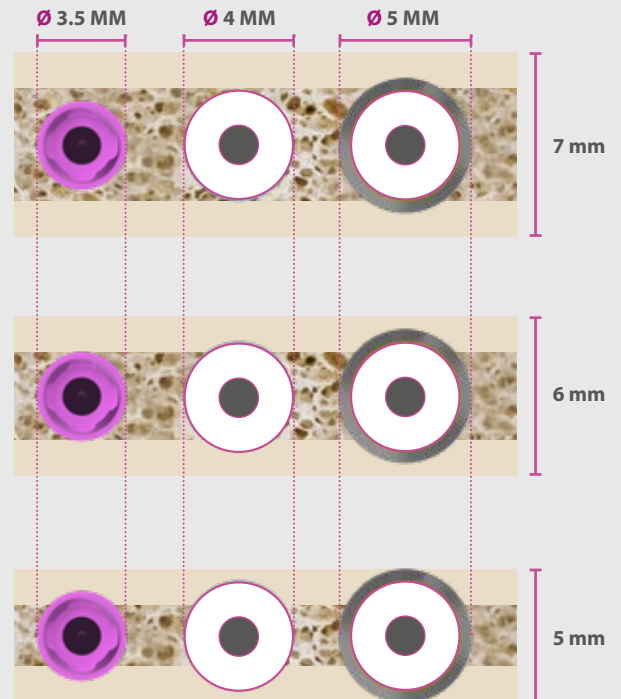

When implants first began to be used in dental rehabilitation clinics, the possibility of requiring subsequent re-treatments wasn't considered. Nowadays, in dental surgery, we increasingly have to re-treat unsuccessful, failed dental implants or ones that are impossible to rehabilitate. Subsequently, considering the reversibility of our surgeries and how we can conserve part of the initial bone volume for this possible second action have led to us being more conservative with the implants that we choose: less is more, less titanium will facilitate the possibility of having to rehabilitate the case afterwards if the first attempt is unsuccessful or has to be replaced in the long term.

Based on this concept, implants with a smaller volume of titanium become especially important, allowing us to obtain the same results as with other implants of greater volume, diameter or length. **Narrow and short implants fit into this concept, as they are minimally invasive treatments that are conservative with the receiving bed.**

# Versatility: BTI CORE® in upper maxilla

## 1 IMPLANT IN UPPER CENTRALS

The upper central incisors present an average mesio-distal diameter of approximately 6-7.5 mm. This is an area of high aesthetic demand, so the reduced CORE platform allows us to preserve a suitable volume of soft tissue, allowing us to raise it with a reduced prosthetic component. The narrow platform also allows us to respect the tooth-implant distances and achieve better three-dimensional positioning to achieve an emergence similar to the adjacent tooth, even in cases of atrophy, which are frequent when an upper central incisor is missing.

The implants that are best suited to this clinical situation are those with diameters of between 3.75 and 4.25 mm, depending on the mesio-distal distance of the tooth to be rehabilitated.

## 2 IMPLANT IN UPPER LATERAL INCISORS

The mesio-distal diameter of the upper lateral incisor is approximately 5 mm. It's a tooth with a low biomechanical requirement and usually has a narrow emergence profile, so a platform like that of the BTI CORE® implant is ideal for its single repositioning. In this clinical situation, we'll use the smaller diameters (3.3 or 3.5 mm) according to the mesio-distal space that is available.

## 3 IMPLANT IN UPPER CANINES

The upper canines are teeth with a large mesio-distal diameter (approximately 5.5 - 6.5 mm) with high functional and biomechanical requirements as they are part of the disocclusion guidance.

The CORE platform adjusts to the aesthetics required for the anterior front and, in this case, as it's an area with a greater biomechanical requirement, we'll opt for diameters greater than 4 or 4.25 mm (depending on the mesio-distal space).

## 4 IMPLANT IN UPPER PREMOLARS

The first and second upper premolars have an approximate mesio-distal diameter of 5.5 mm on average. These teeth have medium biomechanical requirements and a reduced emergence due to their smaller mesio-distal diameter. For this reason, repositioning with a platform like CORE is a good solution as you can opt for 3.75 and 4 mm diameters as a preference.

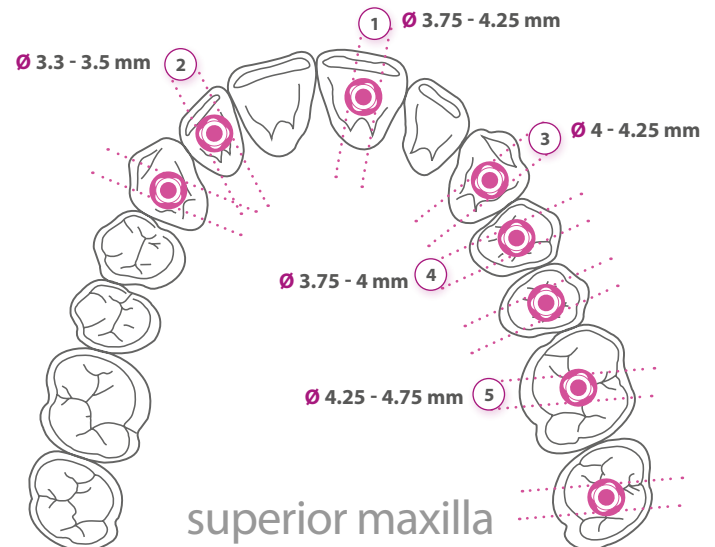

## 5 IMPLANT IN UPPER MOLARS

The upper first and second molars are teeth with a substantial mesio-distal diameter (8.5 to 11 mm) with very demanding biomechanical requirements. BTI CORE® implants can be a valid alternative in their larger diameters (4.25 and 4.75 mm) upon assessment of the residual bone volume and the possibility of splinting between several implants, which would be beneficial in order to reduce their diameter. In cases with large edentulous spaces (13 - 14 mm), a molar restoration with two implants, one per root, may also be valid, in this case, using implants with a smaller diameter to respect the distances between implants.

# Versatility: BTI CORE® in lower maxilla

## 1 IMPLANT IN LOWER INCISORS

The lower central and lateral incisors have a very small mesio-distal diameter ranging between 3.5 and 4 mm on average, accompanied by a narrow emergence. To this end, a reduced platform like that of the CORE line is ideal, opting for smaller implant diameters as, in this area, residual bone volume is usually low, both mesio-distal and bucco-lingual.

## 3 IMPLANT IN LOWER PREMOLARS

The first and second lower premolars have an approximate mesio-distal diameter of 5-5.5 mm on average. These are teeth with medium functional and biomechanical requirements, therefore the recommended diameters are 3.75 – 4 mm.

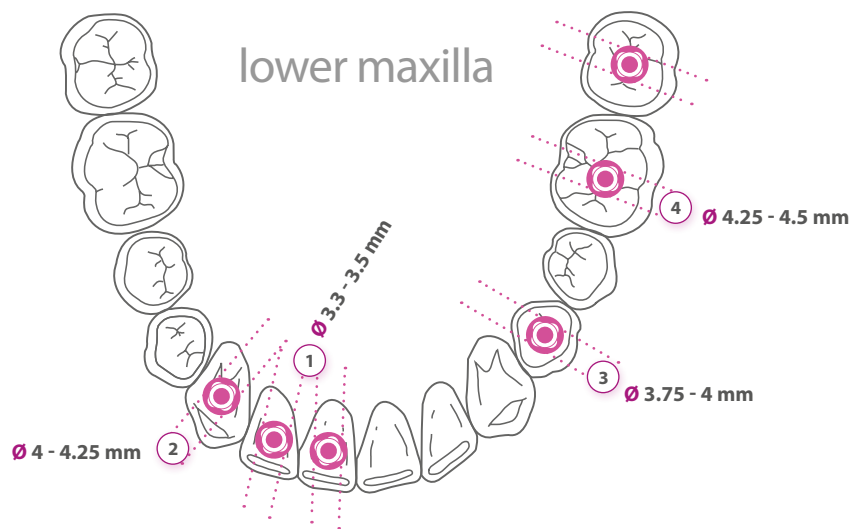

## 2 IMPLANT IN LOWER CANINES

The lower canines are teeth with a large mesio-distal diameter that ranges between 5.5 and 6 mm on average. They have high functional and biomechanical requirements, due to their participation in the different disocclusal guidances, but less than the upper canines. BTI CORE® implants are suitable to provide a solution for the aesthetics of the canine, and they also come in diameters that provide us with the biomechanical stability in bone load distribution required by this anatomical location.

In this case, the suitable diameters are 4 or 4.25 mm (according to the mesio-distal space).

## 4 IMPLANT IN LOWER MOLARS

The first and second lower molars are the teeth with the greatest mesio-distal diameter (10 or 12 mm) and stringent biomechanical requirements. The diameters to be used in this area are those greater than 4.25 and 4.5 mm. In cases where we have a larger space to restore (13 - 14 mm), restoring the molar with two implants may also be valid, one per root, in this case with implants of smaller diameter to respect the distances between implants.

## MULTIPLE REPOSITIONS

Cases of multiple repositioning, when they are extended edentulisms, generally have some type of bone atrophy: vertical, horizontal or mixed. **In cases where there is less residual bone volume, the insertion of narrow platforms and reduced diameters can lead to us changing our therapeutic approach in favour of a more conservative one.** These implants are reliable as long as they are splinted to other implants and represent less morbidity for the patient compared to the regeneration and expansion techniques that would be necessary to resolve bone atrophy favourably.





# CORE

in bone atrophy



## TYPES OF ATROPHY

### VERTICAL ATROPHY

Tooth loss, as well as destructive dental processes (periodontitis, apical infections, etc.), imply a reabsorption of the alveolar process that can be higher or lower depending on the time and severity of the process that affected the osseous bed. This causes vertical (in height) and horizontal (in width) atrophies that can be combined or pure.

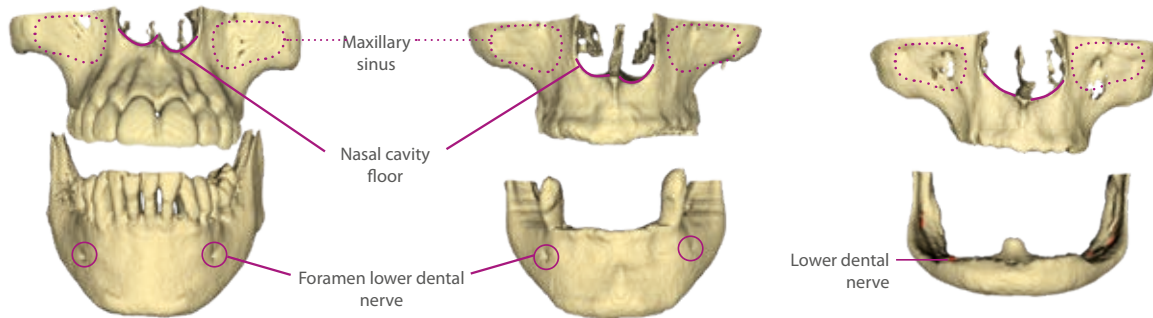

### HORIZONTAL ATROPHY

The loss of teeth brings about different resorption patterns. In general, the most significant decrease after tooth loss occurs in height, although, in some cases, when we have a narrow bone crest to start with, horizontal atrophy can begin at the same time. Dental loss associated with serious infectious processes sustained over time is more likely to create this type of resorption as the vestibular plate is lost and a horizontal collapse occurs after healing of the post-extraction bed.

#### CLASS 1

Partial reabsorption of the lowest part of the vestibular plate, less than 50% of its height

#### CLASS 2

Reabsorption greater than 50% of the height dimension of the vestibular plate without affecting the apex

#### CLASS 3

Full reabsorption of the vestibular plate including the apex

#### CLASS 4

Vestibular and lingual reabsorption

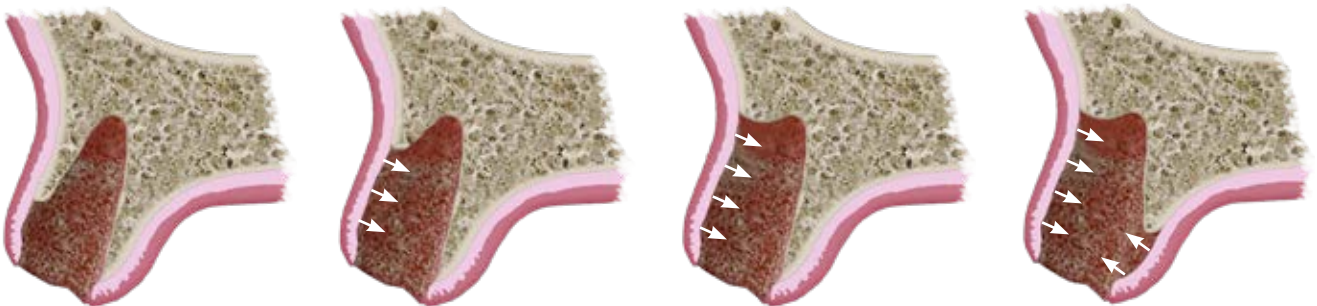

This type of horizontal atrophy can occur both in the mandible and in the maxilla

# Surgical techniques with BTI CORE®

## VERTICAL MANDIBULAR ATROPHY

We can use BTI CORE® implants in the majority of vertical mandibular atrophy cases. On some occasions (when the osseous bed allows for it) we can insert the implant directly, either in an axial position or lingualising it to avoid the dental nerve. In other cases (when we have less residual bone volume) we can gain a few millimetres by placing the implant supracrestally and expanding vertically, or by fixing the apex level with the upper cortical of the dental nerve.

### TREATMENT

The BTI CORE® line of implants has a versatility in terms of diameters and lengths that allows us to treat vertical mandibular atrophy safely and successfully. In this case, we'll opt for the shortest lengths in the range (from 4.5 to 8.5 mm).

**The main challenge that we face with this type of mandibular atrophy in height is the superficialisation of the dental nerve. In some cases, it can range from 27.5 mm in the second premolar area in a mandible with all its dentition, to being submucosal in jaws with extreme resorption.**



### DIRECT INSERTION OF THE IMPLANT

**Carry out the same drilling sequence as for short implants, using the front cutting drill to adapt the morphology of the implant apex to the neo-socket.**

Keep the drills a safe distance away from the dental nerve, approaching it slightly with the front cutting drill.



## SUPRACRESTAL INSERTION WITH VERTICAL GROWTH

Placing the implant above bone level in cases of mandibular atrophy guarantees us extra space up to the dental nerve which is very useful and allows us to insert a longer implant length. **The area of the implant that remains above the level of the ridge is covered with a particulate bone graft obtained from drilling, embedded in PRGF - ENDORET® fraction 2 activated, to achieve bone growth at that level and so that, in the end, the implant is juxtacrestal.** With this technique, we can predictably gain between 0.5 and 1 mm, in more extreme cases we can even attempt up to 1.5 mm. The drilling sequence is the same as for short implants.

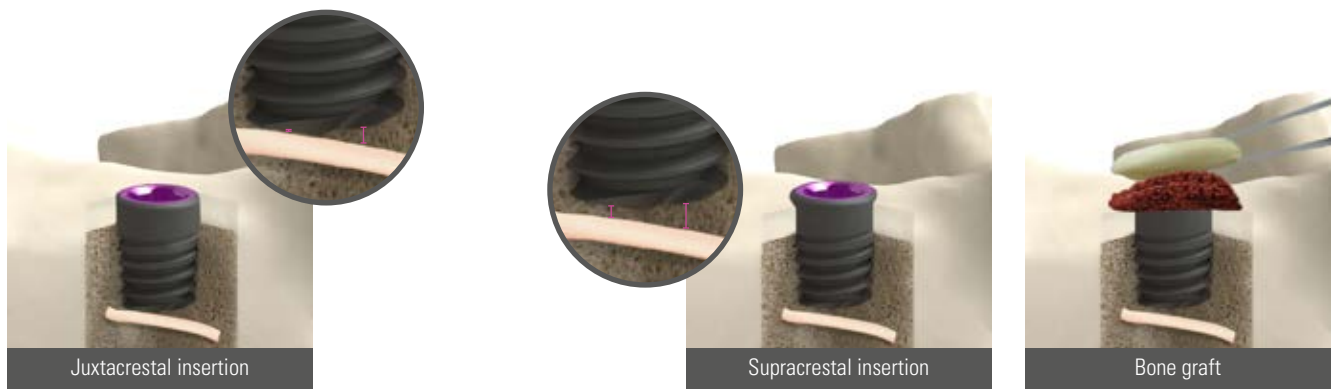

## INSERTION LINGUAL TO THE DENTAL NERVE

In cases where the nerve is high up, with sufficient residual bone volume to position the dental implants lingually, the implants can be inserted in this area. To do this, the area should be drilled carefully, verifying the anatomical references marked in the planning on the dental CBCT. **CORE implants are ideal for this situation as their conical apex guarantees us more space in the critical area, close to the dental nerve.** The different diameters in the range allow us to adapt to the clinical situation safely depending on the available space, leaving the nerve to one side.

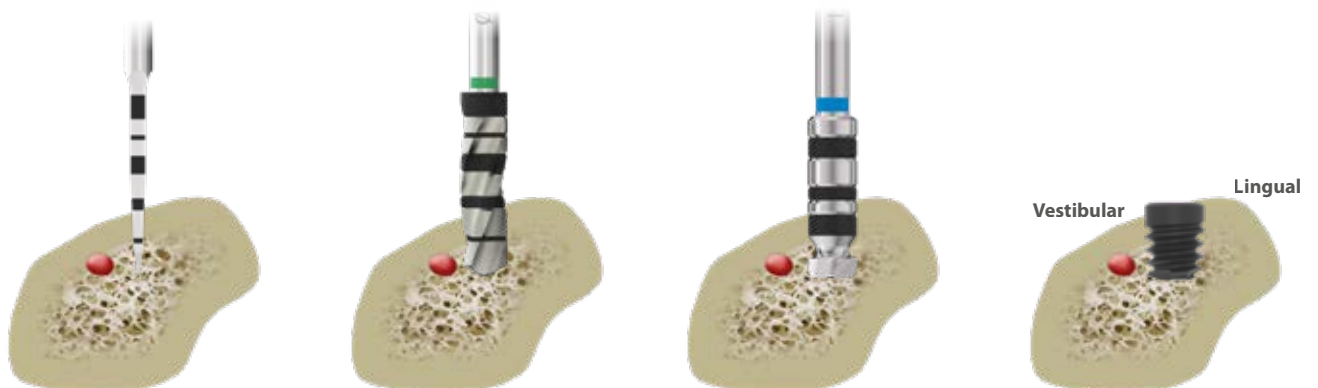

## DRILLING THE CORTICAL OF THE DENTAL NERVE

In cases where bone height is reduced, we can get close by drilling a small section of the cortical of the dental nerve, gaining 0.5 mm if we carry out partial drilling and up to 1 or 1.5 mm if the cortical is drilled completely. This drilling can be done safely with the front cutting drill. To do this, we continue to drill, removing the cortical until we begin to see it disappear in the lower part of the socket, a reddish area appears, that is the dental nerve. We can remove part or all of this canal, always checking drilling advancement with an indirect mirror. When we partially remove the canal, the apex remains fixed to the cortical of the nerve. When total drilling is carried out, the fixing must be achieved in the upper part of the socket as in these cases primary stability and avoiding micro-movements of the implant is key.

### PARTIAL DRILLING

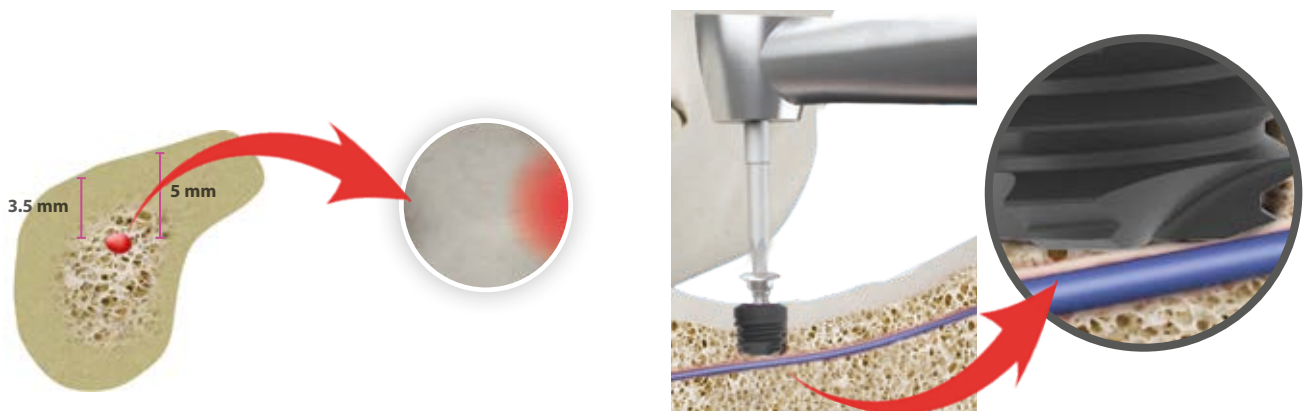

When the vestibular and lingual plate are located at different heights, a slight area of redness may appear at the bottom of the neo-socket, which will indicate that the area where there is less bone volume has been almost completely drilled. This cortical can constitute a suitable fixing point for the apex in extreme situations.

### TOTAL DRILLING

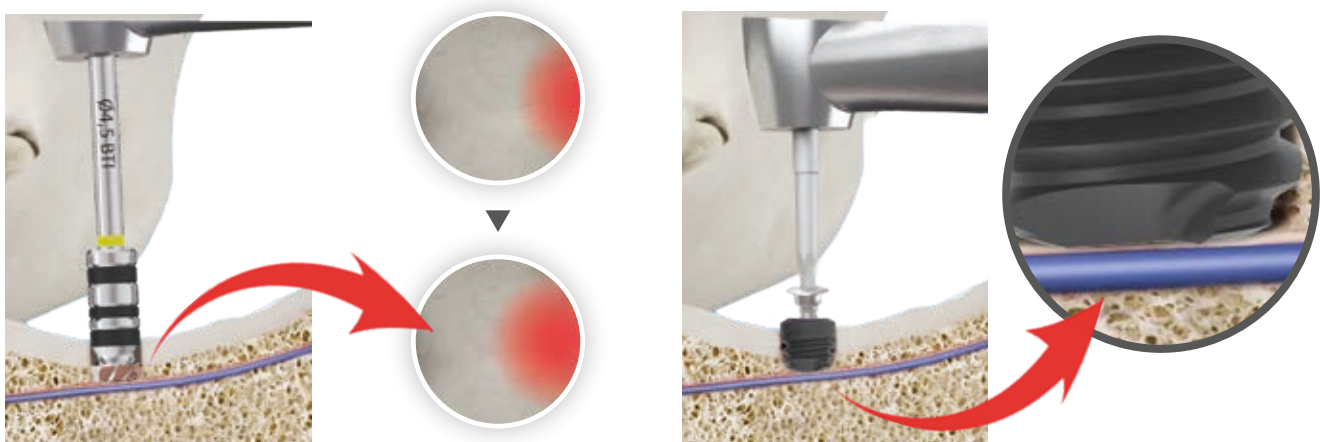

Our drilling should at all times be focussed on the part of the cortical that is most intact, until the upper cortical of the dental canal has been drilled completely.

# Surgical techniques with BTI CORE® in VERTICAL MAXILLARY ATROPHY

Just as with the mandible, CORE offers different alternatives that cover the majority of vertical atrophies that we can expect to find in the maxilla. **In this case, to treat vertical maxillae atrophy, we'll opt for the shortest lengths in the range (from 4.5 to 8.5 mm).**

For the upper maxilla, when there is vertical atrophy, we tend to face two key challenges: maxillary sinus in posterior areas and nasal cavity in anterior areas.

## TRANSCRESTAL ELEVATION

This technique consists in raising the Schneider's membrane to place a graft under it that is later integrated and consolidated, forming a greater bone height. It is performed by perforating the crest (generally the neo-socket), through which drills are inserted that allow us to remove the lower portion of the cortical that separates the sinus, or the nasal cavity, from the residual crestal ridge.

In our protocol, just like with the mandible, **we'll use a front cutting drill to get close to the membrane without damaging it, removing the bone. Afterwards, we'll remove the membrane through the perforation and apply a material that maintains the elevation that we want to achieve.** This material can be:

- 1 Activated and retracted fibrin (*fraction 1*)
- 2 Activated and retracted fibrin (*fraction 1*) + Autologous bone obtained from drilling embedded in PRGF - ENDORET® (*fraction 2 activated*)
- 3 Autologous bone from drilling + PRGF - ENDORET® (*fraction 2 activated*)
- 4 PRGF - ENDORET® (*fraction 2 activated*)
- 5 Simply the apex of the implant.

The choice of one material or another will depend on the space to be elevated: the larger the space, the greater the need for graft volume; and the availability of autologous bone.

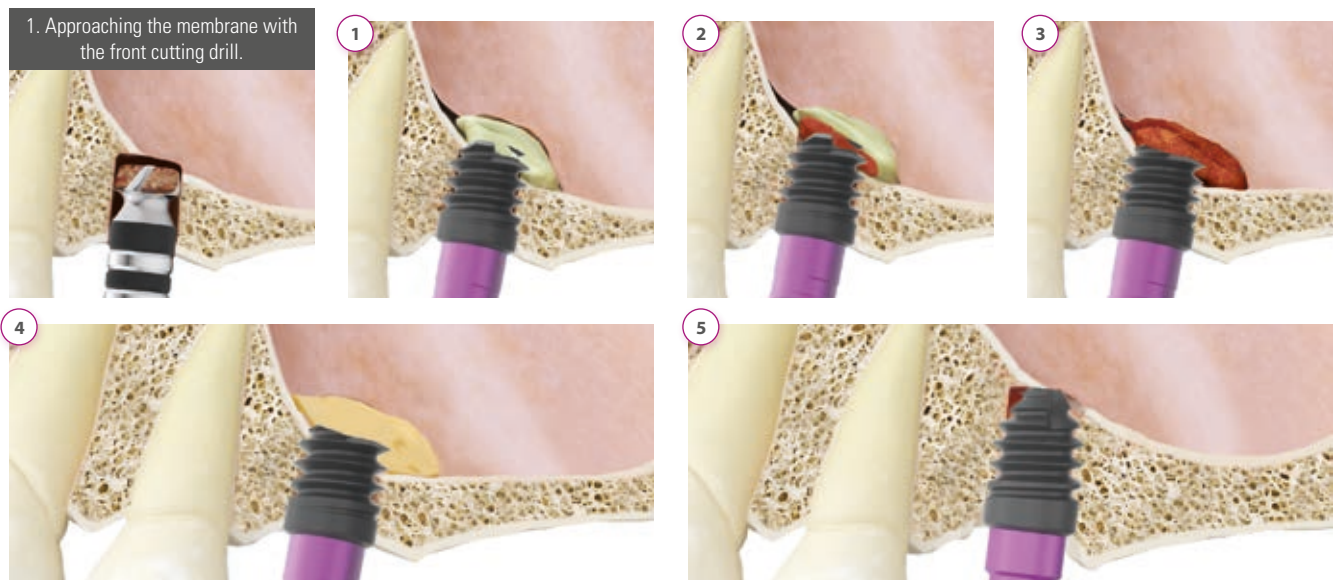

## ELEVATION OF THE NASAL CAVITY

When the height limitation is located in the pre-maxilla, we can perform a small elevation of the nasal cavity in a way that's very similar to the procedure for transcrestal elevation that we described earlier. **In this case, we change the implant insertion axis due to the angle of the bone crest with extreme resorption at this level.**

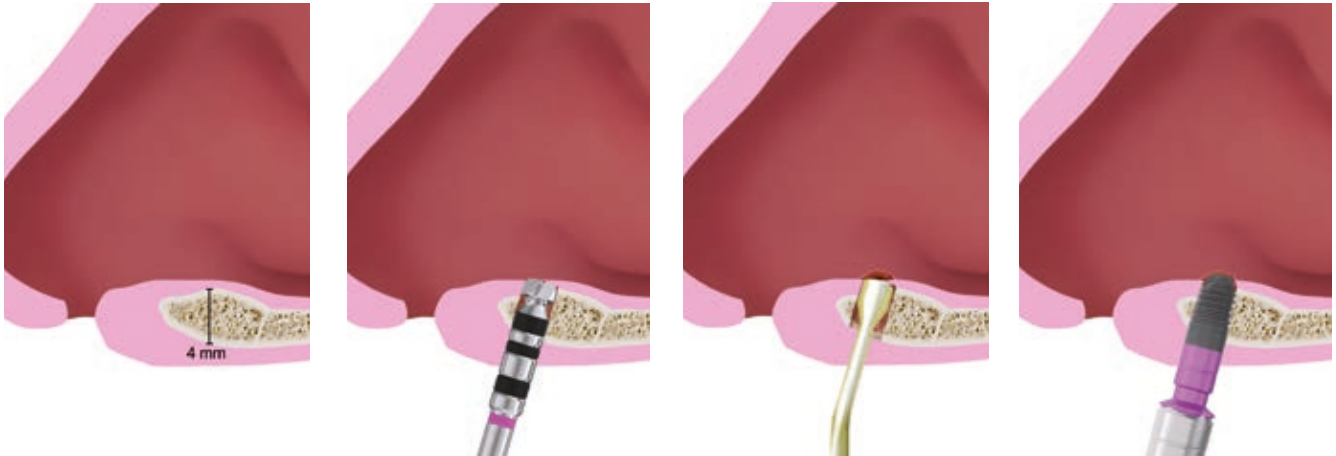

## Surgical techniques with BTI CORE® in HORIZONTAL ATROPHY

### TREATMENT

In the mandible, horizontal atrophy tends to be more frequent in the anterior area (inter-foraminal area), although it can also exist in posterior areas. When the horizontal atrophy is pure (with no or little vertical component), the main drawback that we face when rehabilitating these areas with dental implants is the need to use small diameter implants and, if possible, those with a reduced platform. **BTI CORE® has a narrow platform that perfectly adapts to crests with horizontal reabsorption, minimising additional techniques to recuperate the loss of bone volume in width** (expansions, block grafts or guided bone regenerations), although in extremely complex cases these techniques may be necessary in conjunction with narrow platform implants. Our therapeutic approach will vary depending on the remaining bone width as well as the presence or absence of the vestibular plate.

## DIRECT INSERTION OF THE IMPLANT

This technique is suitable for both maxilla and mandible and when there is sufficient bone volume it will be the priority option. **The drilling sequence given for implants with smaller diameters will be used.**



Insertion of a narrow implant in a crest with horizontal atrophy, where the necessary circumferential bone volume is preserved to avoid its resorption.

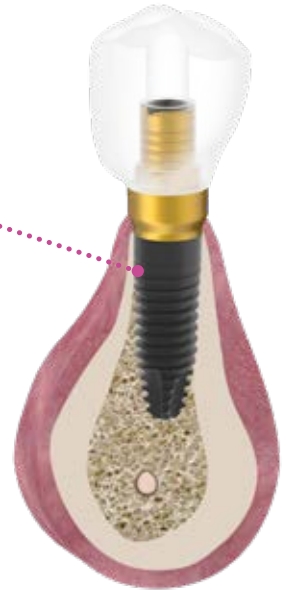

For cases where residual bone volume is low but sufficient for the insertion of an implant, but low density makes it difficult to achieve good primary stability, we can use bone expanders. These enable us to compact the bone out towards the sides, leaving it on the walls of the neo-socket. This way, no bone is lost and the implant is more stable.

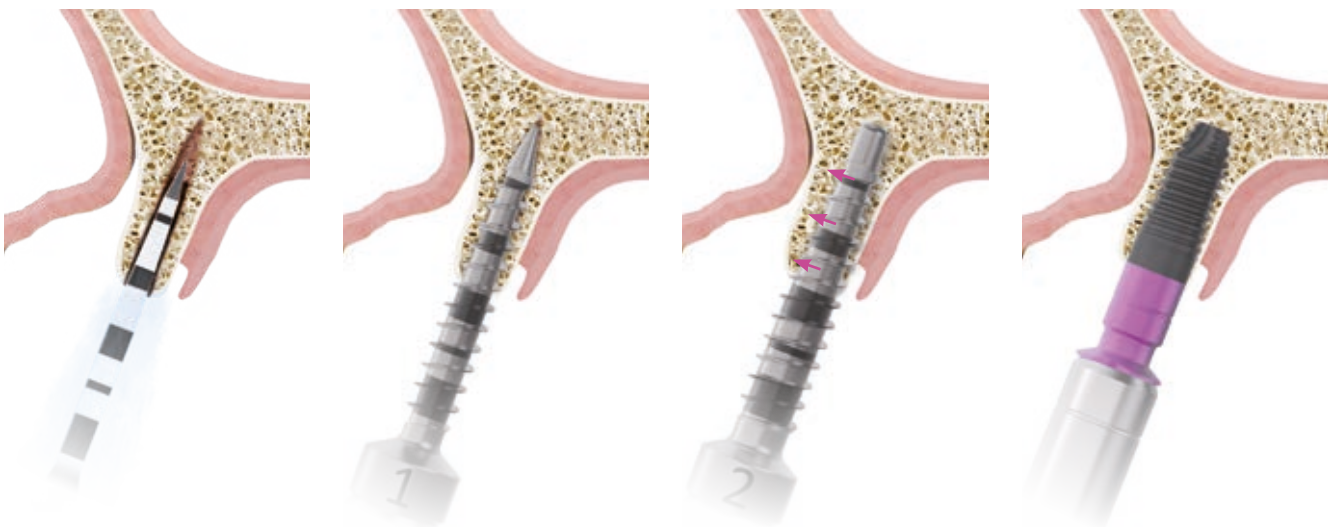

## PERI-IMPLANTITIS: NEW CHALLENGES

Re-treating dental implant cases in our everyday dental practice is an increasingly frequent challenge that we face.

The different protocols for dealing with peri-implantitis offer us different possibilities: mainly the detoxification of the surface and regeneration, mechanical cleaning and resection of the inflamed tissue and extraction of the implant. Making the surface of the titanium bacteria-free once it has been exposed to the oral environment is practically impossible, which is why, increasingly, when there are recurrent infec-

tions extraction of the implant is recommended. In different studies published by our group, we have produced a new treatment algorithm for peri-implantitis, according to which, in cases where we consider it impossible to recolonise the lost bone or to achieve optimal cleaning of the implant, it's best to opt for the atraumatic extraction of the implant and the re-treatment of the bed (in one or two phases, depending on the case).

# Protocol PERI-IMPLANTITIS

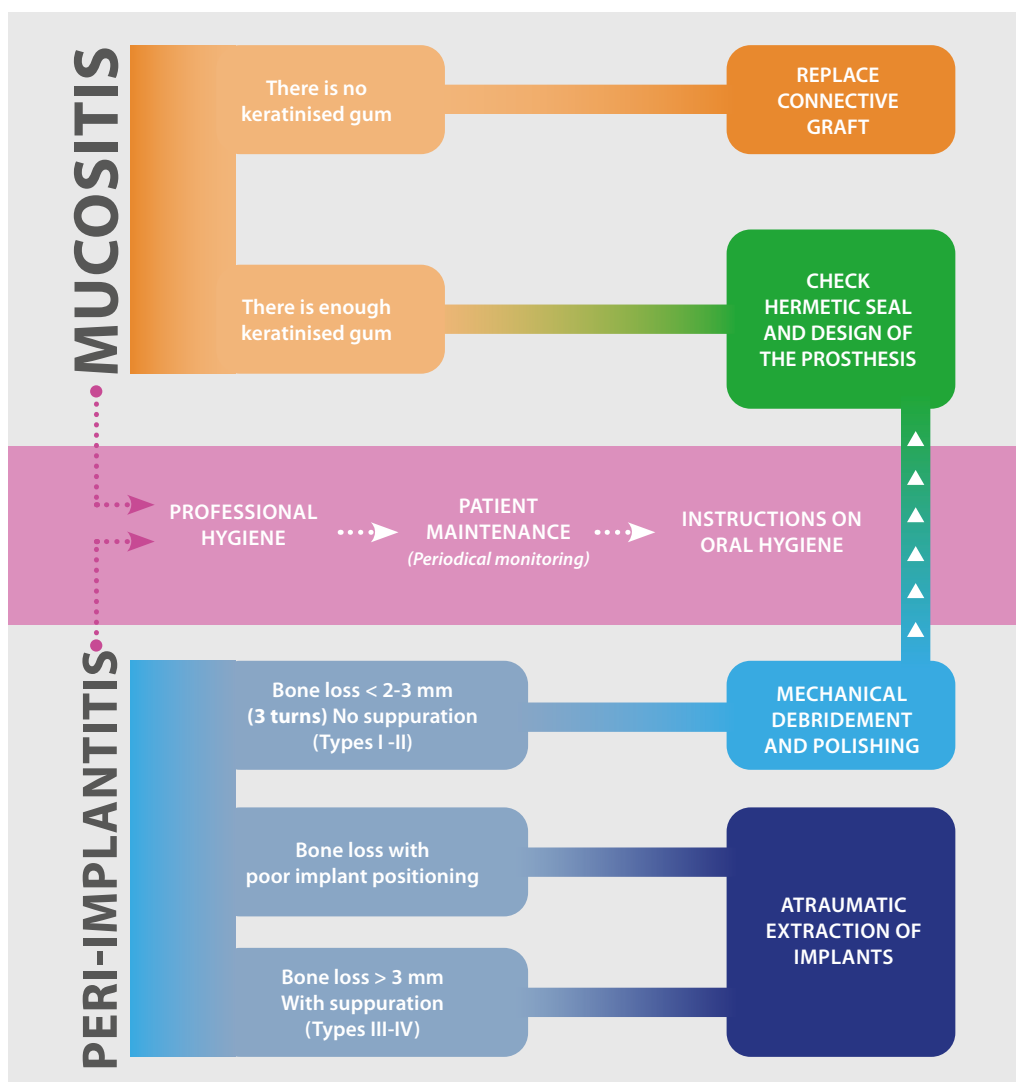

## LESS TITANIUM: REVERSIBILITY OF OUR TREATMENTS

In this case, when we choose to extract and re-treat with implants, not having used all of the available bone volume in the first treatment is a key differential factor.

The use of implants like BTI CORE® which have a reduced platform and a conical body, allows us to use less bone volume in rehabilitation with implants and to preserve the bone in view of the reversibility of the treatment we are performing.

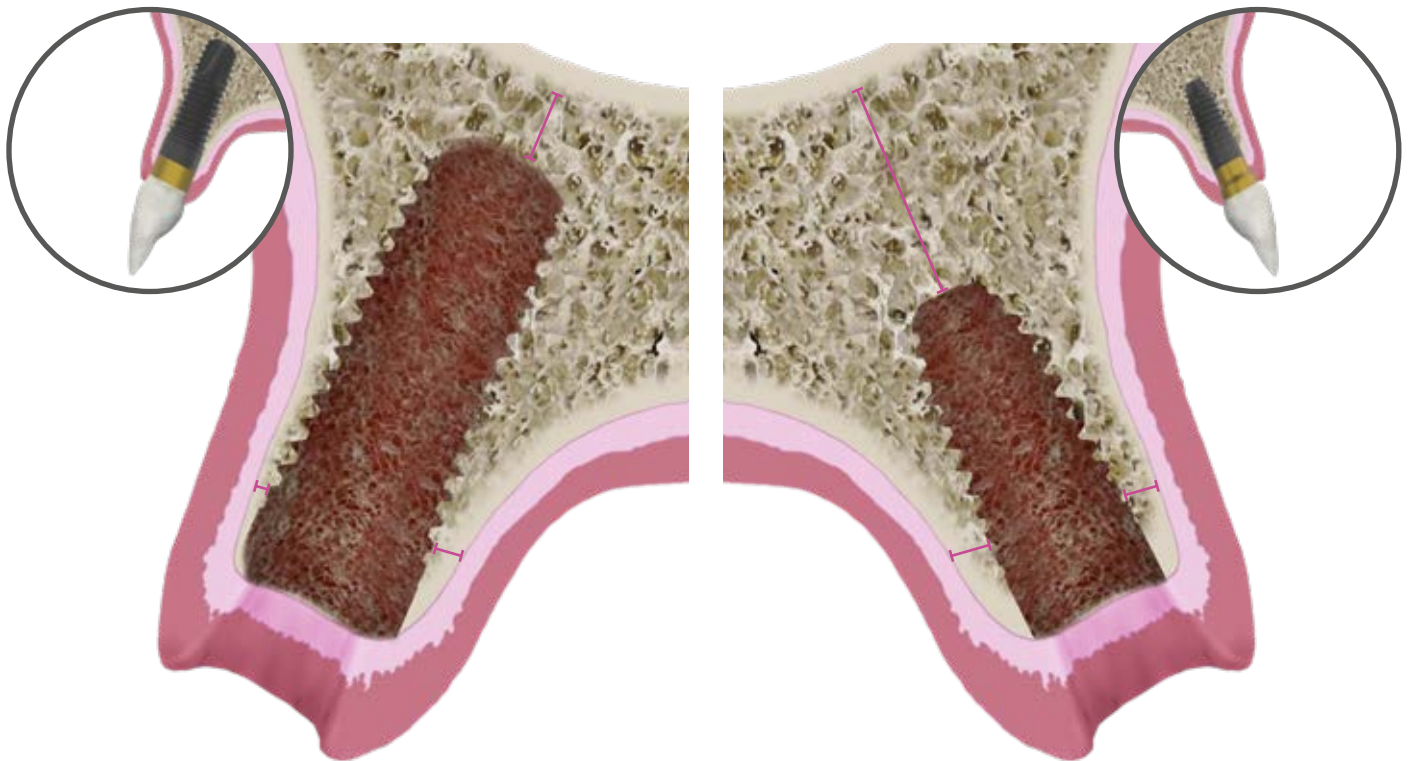

Preserving part of the osseous bed that is available for the insertion of implants can mark the difference between being able to re-treat a patient with failed implants in a relatively simple way or having to do so with more complex treatments.

In some cases, when the failed implant is removed and there is sufficient residual bone volume, we can insert a new one in the same surgical procedure, reducing treatment times and surgeries.

Conventional implant extraction methods (trephining, bone removal through drilling and dislocation of the implant) cause extensive damage to the bed where the implant was which, in most cases, makes it impossible to place a new implant in the same area following extraction.

To resolve the problem of rehabilitation after the failure of a dental implant, the concept of atraumatic extraction came about, allowing the implant to be removed conservatively from its bed and, in many cases, allowing another one to be inserted in the same position and during the same surgical procedure. The counter-torque implant extraction technique has shown high predictability for breaking the bone-implant junction with minimal trauma compared to conventional methods (drills or trephines).

## EXPLANATION KIT

All of the research centred on the development of this kit was mainly based on two fundamental pillars:

- Achieving the "de-osseointegration" of the implant in a way that was easy and accessible to any clinician.
- Being as conservative as possible with the bed in which the implant is seated in order to (in some cases) place an implant immediately post-explantation or regenerate the defect in a predictable manner.



This wrench has a torque limit of 200 Ncm. Once that torque has been reached, the shank of the wrench rotates 20°, thus avoiding generating injuries due to shearing or breakage of the bone and fractures of the extractor or of the implant.

The transport handle allows us, in combination with the extenders, to fit the extractor correctly in the connection, making it easier to adjust.

The extenders are the intermediate parts that connect the torque wrench with the implant extractor. They are sold in three lengths to adapt to all clinical situations.

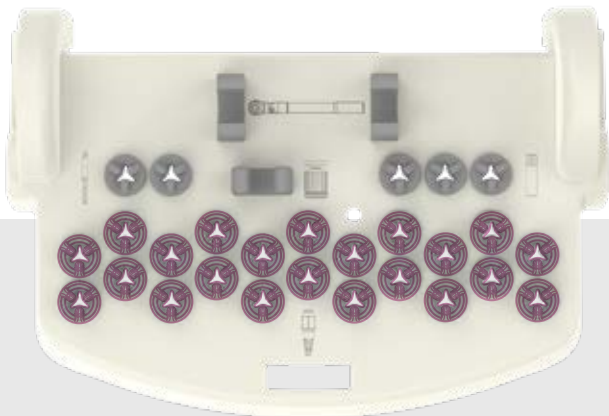

Two drills are included that make it possible to adapt complex connections to the geometry of the extractor



**DRILLS**

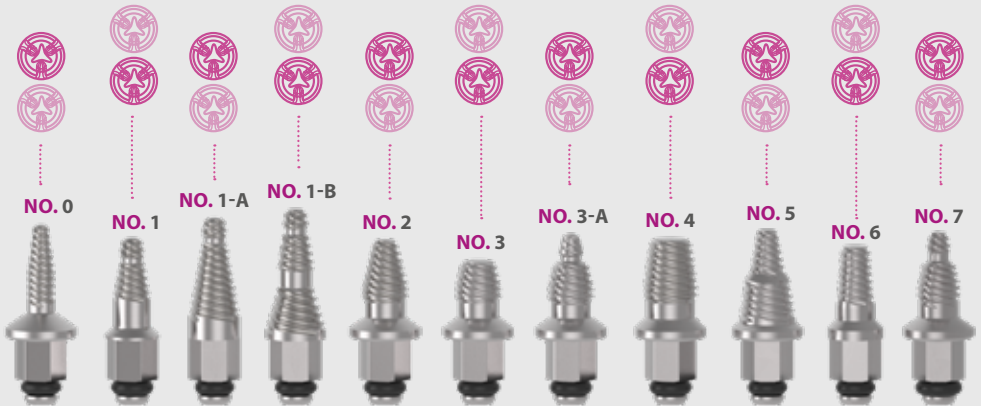

**EXTRACTORS**

(One of each included)

## GENERAL USE

The first step is to insert the extractor following its axial shaft into the connection of the implant, anti-clockwise. For this purpose, use the transport handle that, when joined to the extender, becomes a tool similar to a manual screwdriver that will provide the accuracy necessary to generate good fit of the extractor in the position and axis desired.



*Insert the extractor anti-clockwise into the implant connection.*

Once the extractor is in position, remove the handle and insert the 200 Ncm extraction wrench. Once connected, start turning it anti-clockwise continuously and maintaining the axial angle of the wrench-extractor-implant at all times, to avoid flexion movements that could fracture the implant or the extractor.

Before the wrench disengages, maintain the tension until the implant begins to be extracted, as the osseointegration is broken. Once this has occurred, continue removing the implant gradually with the wrench until it is fully extracted.

Once the implant has been extracted, the complete preservation of the bed where it was located makes it possible to insert a new implant in the same surgery. For this purpose, we recommend drilling the extraction area and then inserting an implant with a larger diameter than the one extracted, **as long as there is enough residual bone volume for this.**

**If after maintaining the tension for 20 seconds anticlockwise the implant has not begun to be extracted, repeat up to three times.** If it still does not come out, apply torque until the wrench disengages and, if this still does not work, make the wrench disengage up to three times before using the extraction kit with the trephine.



Manually insert the extractor in the implant thread, using the handle-adapter, ensuring it fits in an anti-clockwise direction.

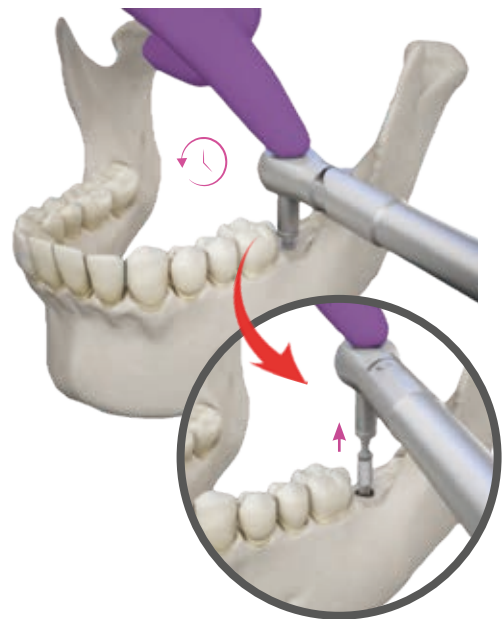

**WARNING:** if the extractor (no. 1, 1A or 1B) does not make contact with the connection of the implant in the upper tapered part, in other words it only makes contact in the area of the thread, you must use the wrench LLMQ at a torque of 70 Ncm instead of the wrench LLT200.



# CORE

restorative protocol



# TYPES OF REHABILITATION

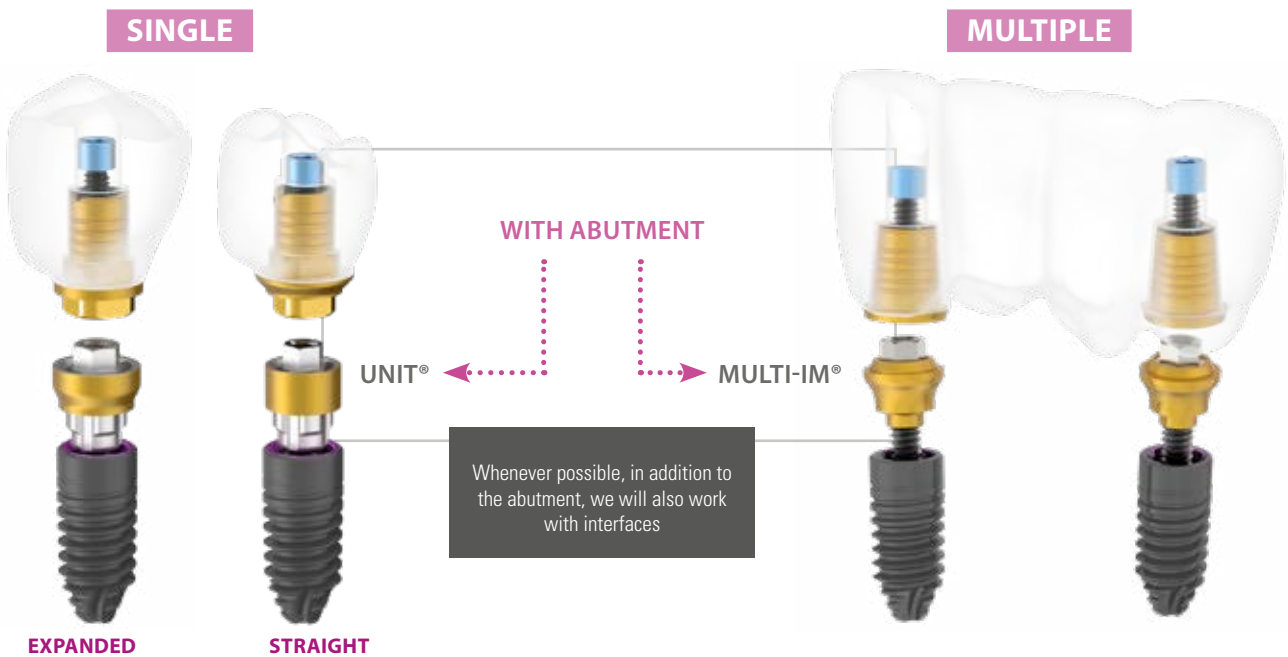
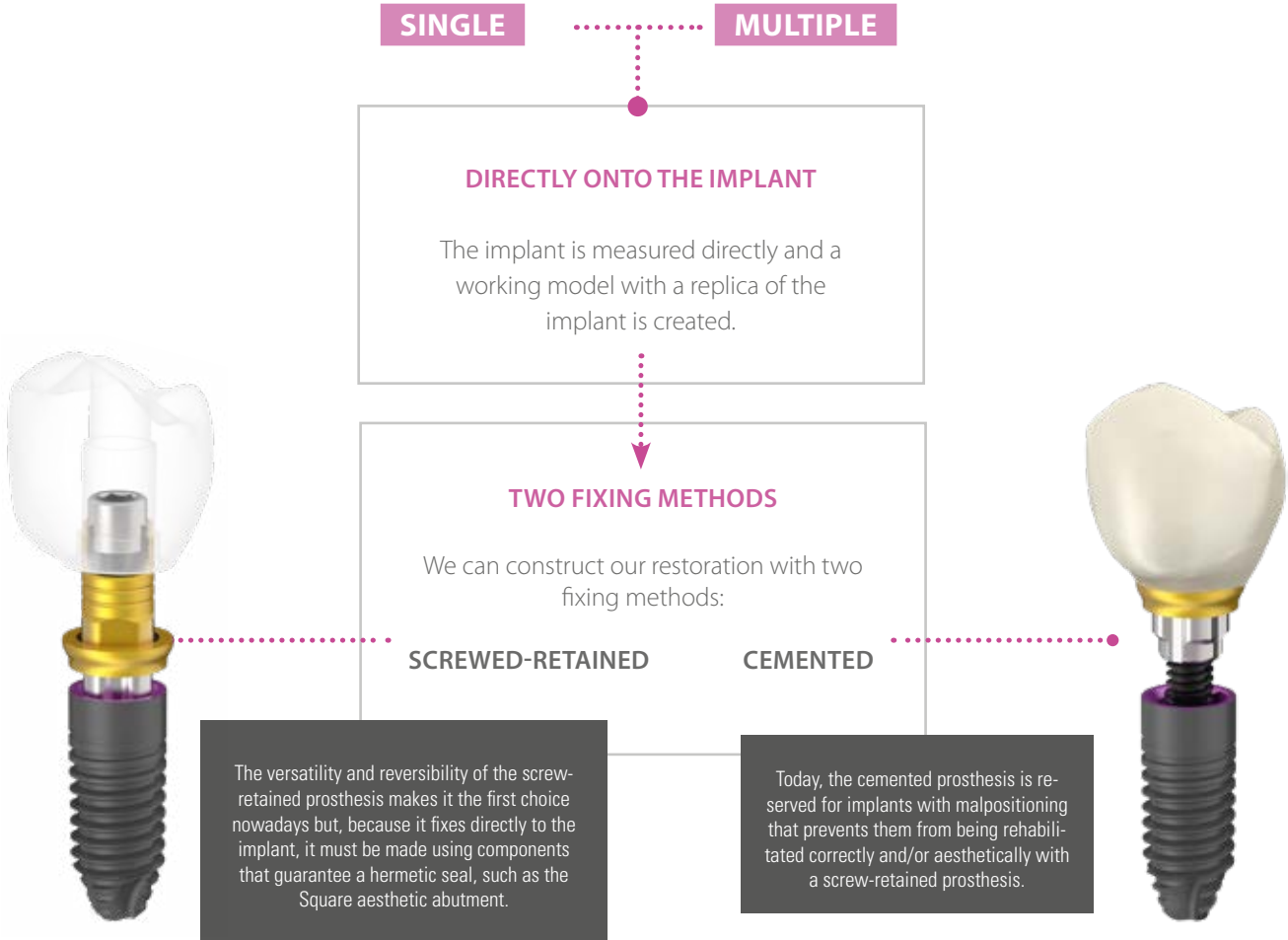

# Types of restoration

## DECISION ALGORITHM

Decision tree on the use of the screw-retained or cement-retained prosthesis depending on the clinical case. Taken from: Wittneben JG, Joda T, Weber HP, Brägger U. Screw retained vs. cement retained implant-supported fixed dental prosthesis. Periodontology 2000, Vol. 73, 2017, 141–151.

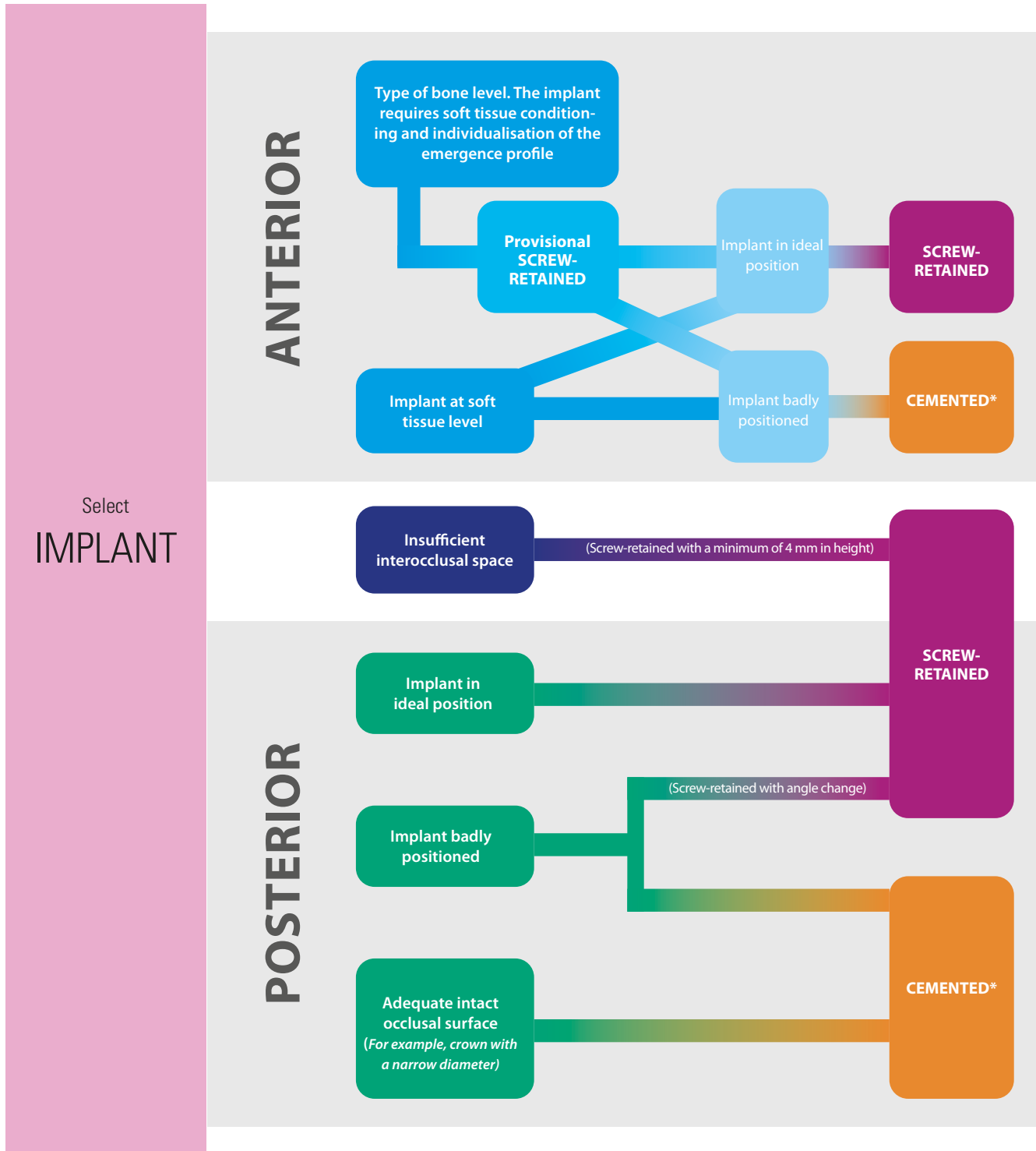

## SINGLE PROSTHESIS

### SCREW-RETAINED DIRECTLY TO THE IMPLANT

The prosthetic components to be used for **single prostheses must have anti-rotation elements**, if not, the prosthesis will rotate on the implant leading to obvious prosthetic misalignments.

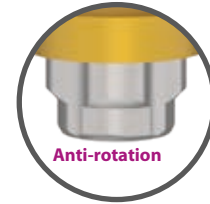

**The component that we recommend for creating the screw-retained crown with suitable aesthetics, a good fit and hermetic seal is the square abutment.** This abutment comes in different heights to suit different gingival heights. A casting cylinder is used that allows the crown to be made on the abutment in different materials (metal-ceramic or ceramic) and using a conventional or CAD-CAM procedure. This cylinder guarantees less thermic cycles for the component that will fit onto the implant: the abutment.

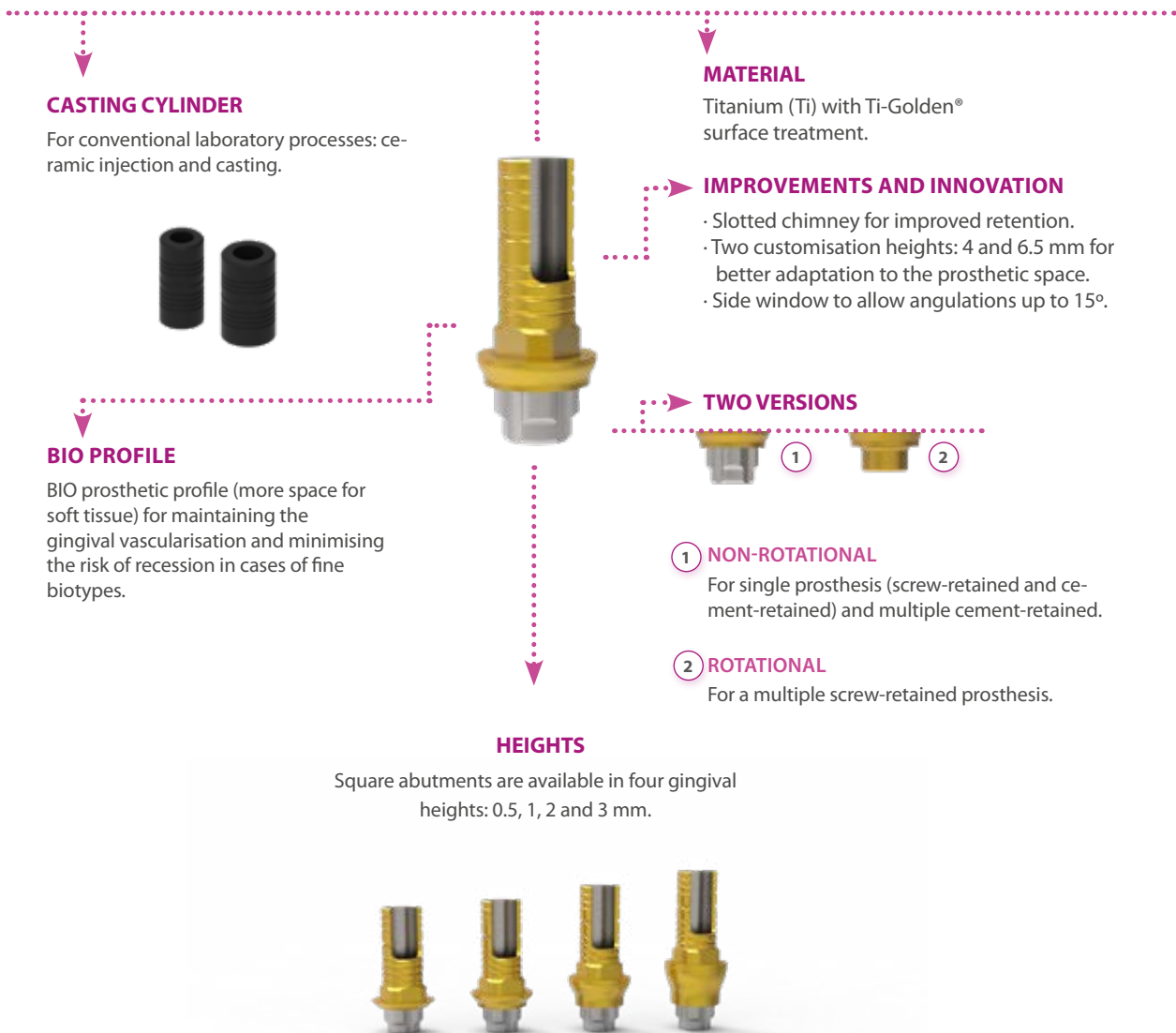

## CEMENTED DIRECTLY TO THE IMPLANT

Cement-retained prostheses are joined to the implant using a personalised abutment post (screwed to the implant) onto which the crown is stuck. In this case, the prosthesis is retained by the bonding agent (cement).

The recommended abutment is Square which, because of its casting cylinder sleeve, allows us to create a totally customised abutment using different procedures\* and materials, making it a versatile option with a good hermetic seal and fit in terms of implant connection.

## CUSTOMISED ZIRCONIUM ABUTMENT USING CAD-CAM

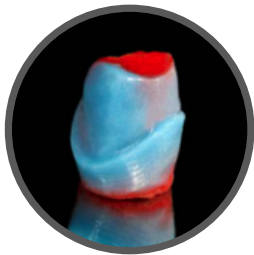

## CUSTOMISED CERAMISED ABUTMENT



## METAL ABUTMENT

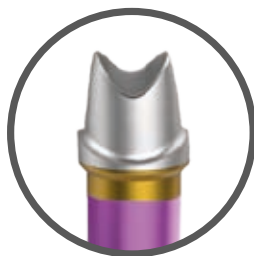

## BY MEANS OF AN INTERMEDIATE COMPONENT: UNIT® ABUTMENT

Creating the crown using an intermediate element grants us a good fit, full conservation of the hermetic seal and maintenance of the bioblock concept, making it an option that we recommend whenever possible. The abutment is inserted according to the area in which we are working (anterior or posterior) and its aesthetic impact at different levels: juxta, sub or supragingival.

The abutments have different gingival heights to adapt to different clinical situations and there is also an expanded emergence profile to modify the platform even more in posterior sectors (molar area)

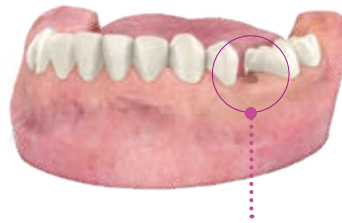
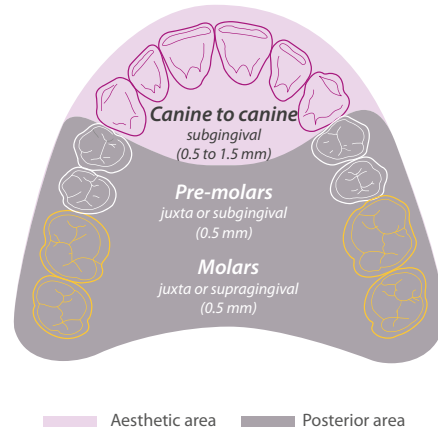

### 4 RESTORATIVE OPTIONS

**EXPANDED UNIT® + INTERFACE**

Expanded UNIT®  
Allows you to open an emergence of 4.1 or 5.5 mm ø.

Heights (4.1 ø)  
2 - 2.5 - 3 - 3.5 - 4 - 5 mm

Heights (5.5 ø)  
2.5 - 3 - 3.5 - 4 mm

**STRAIGHT UNIT® + INTERFACE**

— This allows the contour to be modified and customised in recommended cases, such as central and upper premolars.

Straight UNIT®  
Preserves the same emergence of the implant.

Heights  
1.5 - 2 - 2.5 - 3 - 3.5 - 4 - 5 mm

Expanded UNIT® + Expanded interface

Expanded UNIT® + Straight interface

Straight UNIT® + Straight interface

Straight UNIT® + Expanded interface

Whether you choose one combination or another will depend on the area to be restored and will have an influence on gum gain, which will also depend on the biotype of the patient and the gingival profile to be achieved.

With this type of single abutment, we work using an interface that allows us, with a casting cylinder, to create a versatile prosthesis in terms of manufacturing material and techniques, with angulation by CAD-CAM of the screw chimney even being possible, as shown in the following diagram.

# Working mode

## INTERFACES FOR UNIT®

### CASTING CYLINDERS

For conventional laboratory processes: ceramic injection and casting.

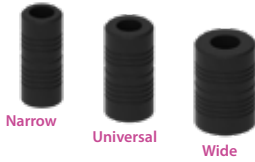

### MATERIAL

Manufactured in titanium (Ti) with Ti Golden treatment

### CONNECTION

Connection design for the anti-rotational component of the UNIT® Abutment.

### ANGLES FROM 0° TO 15°

#### STRAIGHT UNIT®

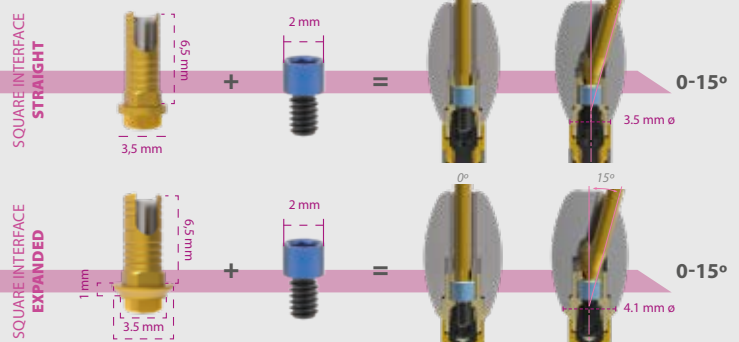
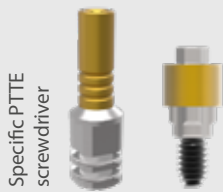

#### EXPANDED UNIT® (4.1 Ø)

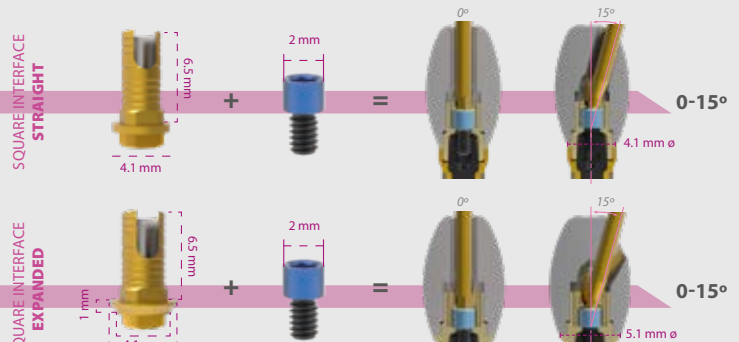
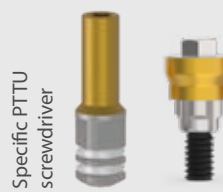

#### EXPANDED UNIT® (5.5 Ø)

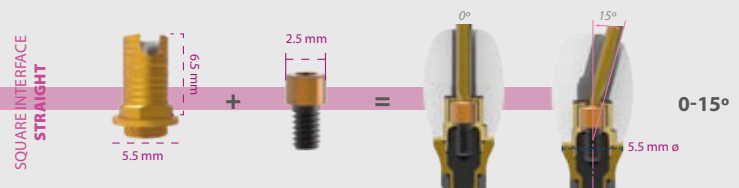

### ANGLES FROM 0° TO 30°

#### EXPANDED UNIT®

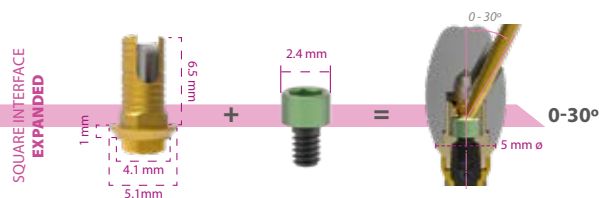

# Working mode ABUTMENT UNIT®

## IMPRESSION TAKING

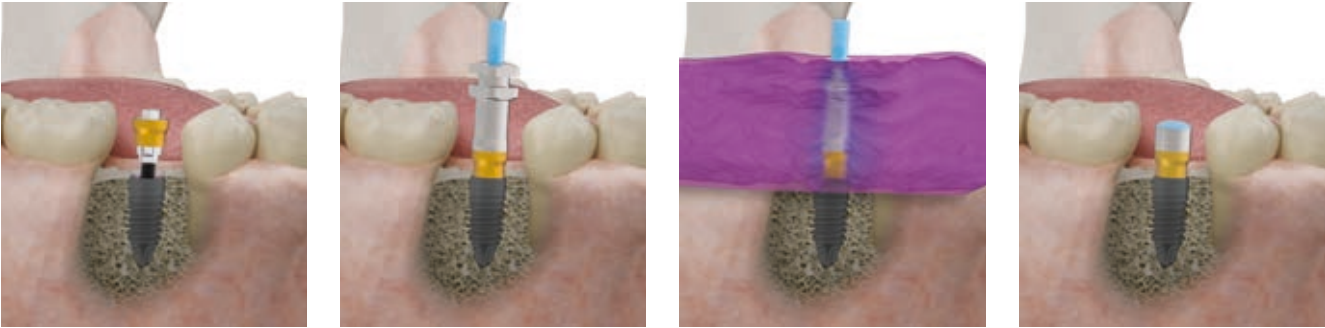

## WAX-UP AND PREPARATION (different modes of working)

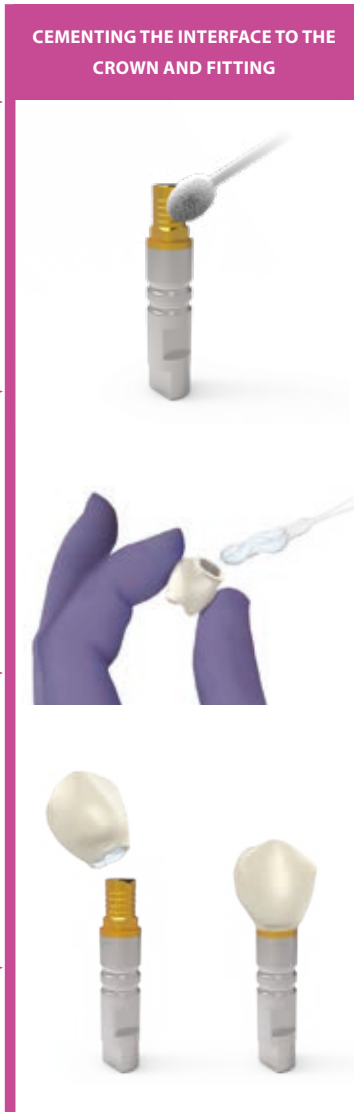
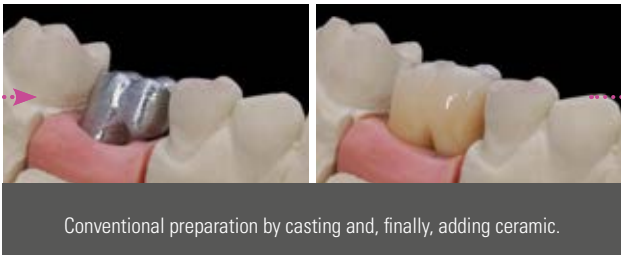

## MULTIPLE PROSTHESIS

We consider a multiple prosthesis to be one with two or more prosthetic parts. Just like the single prosthesis, it can be screw-retained or cemented. **The screw-retained prosthesis can be made, like the single one, directly to the implant or with an intermediate component or abutment which, in this case, is a MULTI-IM®.**

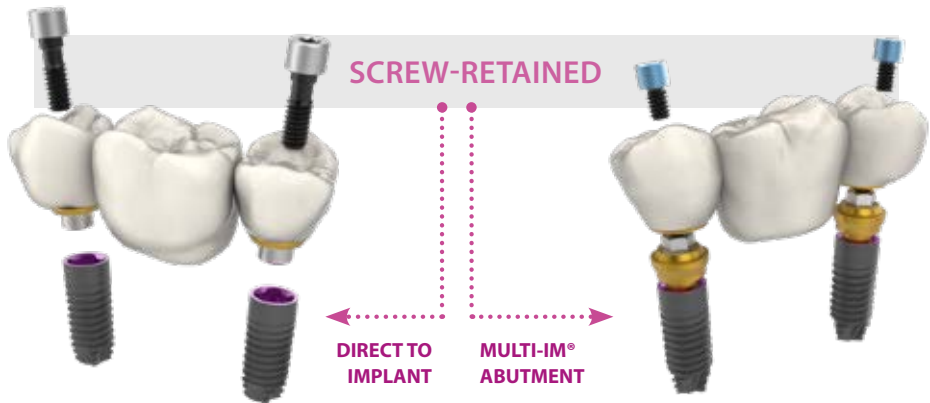

Achieving a good passive fit and hermetic seal when fitting a direct-to-implant multiple prosthesis is very complex because there are problems involved in the impression taking that, when there is a slight disparallelism, can generate tensions in the implant and inaccuracies in the measurement subsequently causing misalignments from the outset. Therefore, we recommend using a screw-retained prosthesis and, if possible, an intermediate component to benefit from all of the advantages of BIOBLOCK®.

**When working on an abutment, we can take the impressions directly and do all of the work on the MULTI-IM® that was initially fitted.** This favours epithelial bonds and simplifies the protocols for taking measurements and creating the working model.



The MULTI-IM® for CORE comes in different heights, emergences and even angles, to suit all clinical situations.

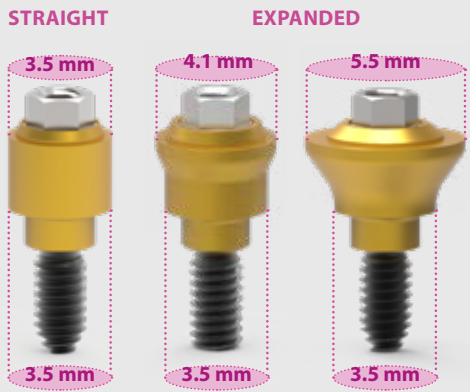

HEIGHTS				
Straight	Expanded		Angled	
3.5 ø	4.1 ø	5.5 ø	17°	30°
0.5 mm	1.0 mm	2.0 mm	1.5 mm	1.5 mm
1.0 mm	1.5 mm	2.5 mm	2.0 mm	2.0 mm
1.5 mm	2.0 mm	3.0 mm	3.0 mm	3.0 mm
2.0 mm	2.5 mm	3.5 mm		
2.5 mm	3.0 mm	4.0 mm		
3.0 mm	3.5 mm	5.0 mm		
3.5 mm	4.0 mm			
4.0 mm	5.0 mm			
5.0 mm	6.0 mm			



# MULTI-IM<sup>®</sup> specifically for 4.5 MM IMPLANTS

The new extra-short 4.5 mm implants only work with multiple screw-retained restorations on an MULTI-IM<sup>®</sup> abutment. If we do not use the compatible abutment in the rehabilitation, it will not sit correctly on the implant, creating a *gap*, as well as displacing the screw connecting it apically, preventing the subsequent fitting of the prosthetic components, as shown in the following diagrams:

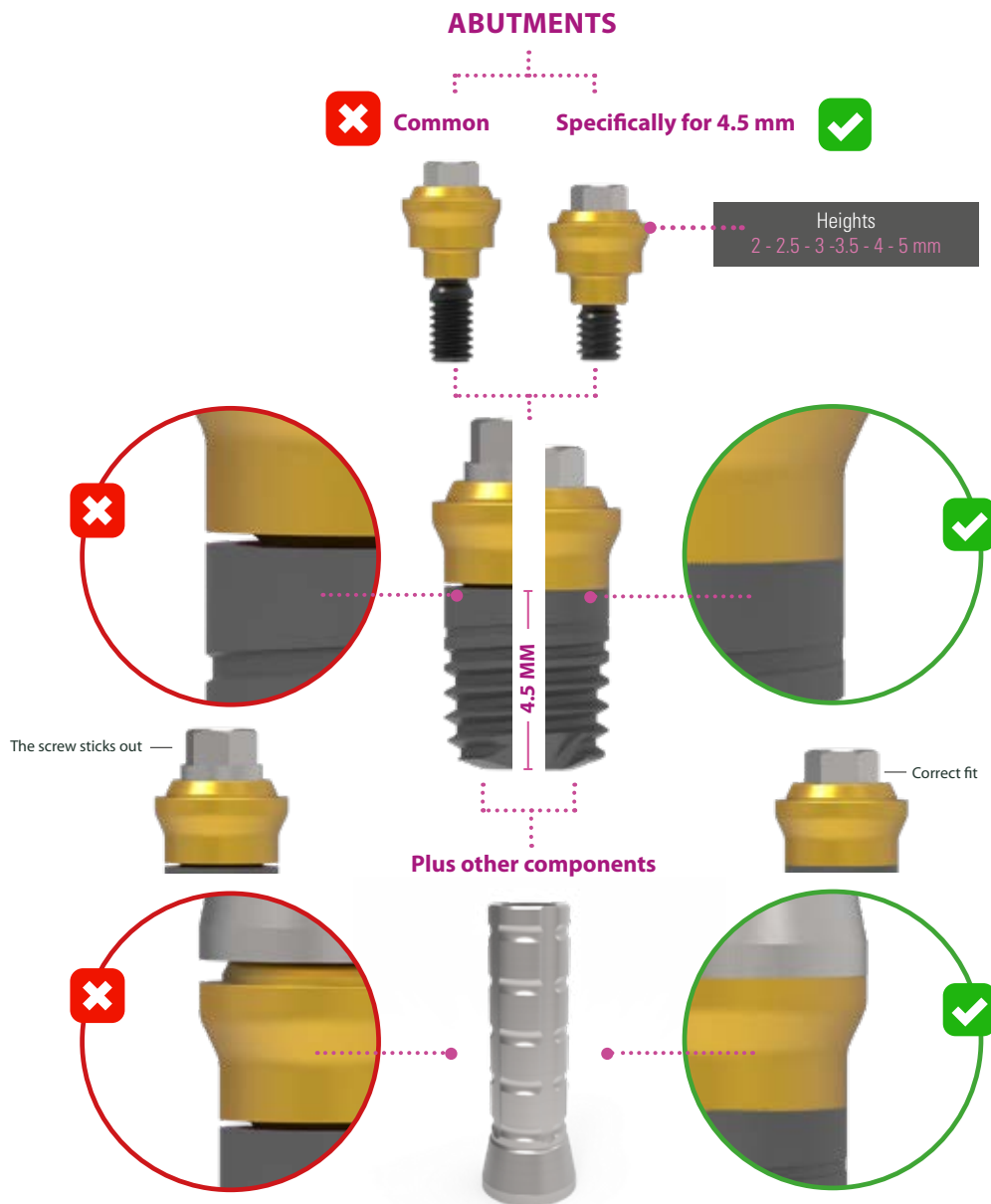

As the common abutment doesn't settle correctly in the implant, the screw prevents all of the prosthetic components that we add from reaching the level of the abutment platform.

All of the components for creating the structure on the MULTI-IM<sup>®</sup> abutment are fully compatible with this new specific design, given that the upper part has the same measurement.

# Working mode

## MULTI-IM® ABUTMENT

### CASTABLE CAST-TO CYLINDERS



This technique uses cylinders that sit on the abutments. The prosthesis structure is made on these cylinders. The prosthesis is finished with the cast-to of the cylinder seat in the chosen material.

### USE OF INTERFACES

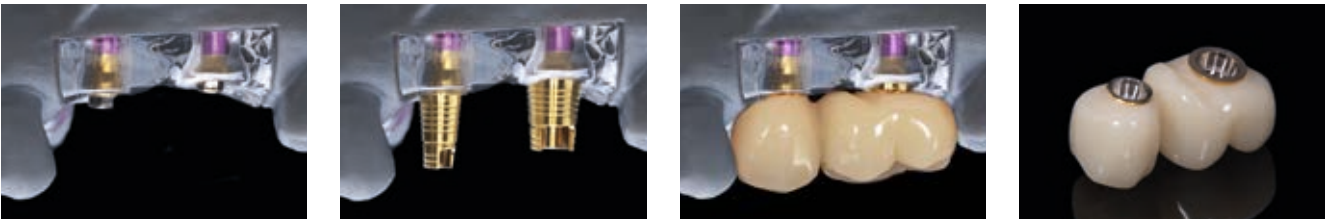

The interfaces act like cylinders to build the structure and cement it afterwards once it is complete.

### USING CAD-CAM

#### A BY USING A PATTERN

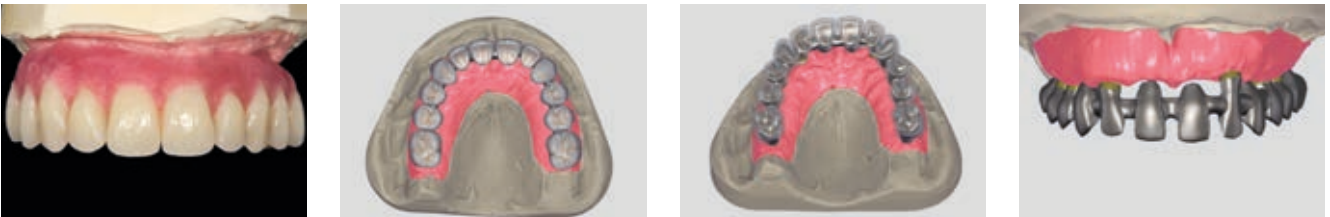

We can make a model of the bridge on casting cylinders and a wax-up of the full size prosthesis on this. This morphology will be scanned and manufactured using CAD-CAM, subsequently making the reduction for the ceramic coating or making a bar for resin in the design program (CAD)

#### B FULL PRODUCTION USING CAD-CAM



For this technique, we only scan the model using the scan-bodies to get a reference that can be transferred to the design program that will tell us the position of the implants. Subsequently, the entire design process of the structure to be machined is carried out with interfaces that allow us to make several prosthetic variants and use different manufacturing techniques.



